

DEPARTMENT OF THE ARMY TECHNICAL MANUAL

---

**OPERATOR, ORGANIZATIONAL, DIRECT  
AND GENERAL OPERATOR,  
ORGANIZATIONAL, DIRECT AND  
GENERAL SUPPORT, AND DEPOT  
MAINTENANCE MANUAL INCLUDING  
REPAIR PARTS**

**GENERATOR SET, GASOLINE ENGINE:  
0.125 KW, AC, 115 V, SINGLE PHASE,  
400 CYCLE; SPECIAL PURPOSE;  
PORTABLE; W/CARRYING CASE  
(HOMELITE MODEL XLA115/1/400-1P)  
SERIAL NUMBERS 2,330,386  
THROUGH 2,331,917 FSN 6115-930-9498**

---

**This copy is a reprint which includes current  
pages from Changes 1 through 3**

**HEADQUARTERS, DEPARTMENT OF THE ARMY**

**JULY 1967**

## **SAFETY PRECAUTIONS**

### **BEFORE OPERATION**

Never operate the generator set indoors without providing piping to vent the exhaust fumes outside of the building. The exhaust fumes contain carbon monoxide, a colorless, odorless, deadly poisonous gas..

Do not operate the unit on a flammable base.

When filling the fuel tank, always maintain metal-to-metal contact between the generator set and fuel container to prevent static sparks from igniting the fuel.

### **DURING OPERATION**

To prevent burns, avoid touching the muffler during operation.

Do not fill fuel tank while engine is running. Set switch to OFF.

The output of this generator set is great enough to cause painful electrical shocks. Observe normal precautions to prevent shock during the operation of this set.

### **AFTER OPERATION**

Shut off engine before cleaning, adjusting, or moving the generator set.

When unscrewing fuel cap, keep face and eyes turned away from fuel tank. Fuel expands greatly when heated and agitated, and may be discharged from tank when cap is removed.

To allow for fuel expansion, never fill fuel tank to the top.

To prevent burns, avoid touching muffler until it has been allowed to cool off.

Changes In Force: C1, C2, and C3

CHANGE }  
NO. 3 }

HEADQUARTERS  
DEPARTMENT OF THE ARMY  
WASHINGTON, D. C., 3 January 1975

**Operator's, Organizational,  
Direct Support, General Support, and Depot  
Maintenance Manual Including Repair Parts  
GENERATOR SET, GASOLINE ENGINE: 0.125 KW,  
AC, 115 V, SINGLE PHASE, 400 HERTZ; SPECIAL  
PURPOSE; PORTABLE W/CARRYING CASE (HOMELITE  
MODEL XLA115/1/400-1 P) SERIAL NUMBERS 2,330,386 THROUGH  
2,331,917  
NSN 6115-00-930-9498**

TM 5-6115-403-15, 11 July 1967 is changed as follows:

Title is changed to read as shown above.

Page 2 of Cover. Warnings are added as follow s:

**BEFORE OPERATION:**

**WARNING**

Do not rely on grounding or safety devices to prevent accidents Electrical circuits and equipment are potentially hazardous. Personnel should always exercise caution to prevent injury or possible death due to electrical shock.

**DURING OPERATION:**

**WARNING**

Operations of this equipment presents a noise hazard to personnel in the area. The noise level exceeds the allowable limits for unprotected personnel. Wear ear muffs or ear plugs which were fitted by a trained professional.

**AFTER OPERATION:**

**WARNING**

Dry cleaning solvent, Fed Spec P-D-680, used to clean parts is potentially dangerous to personnel and property; Do not use near open flame or excessive heat. Flash point of solvent is 100F (38c) - 138F (59c).

Page 1-1, Paragraph 1-1, subparagraph d is superseded as follows:

d. You can improve this manual by recommending improvements, using DA Form 2C28 (Recommended changes to Publications and Blank Forms) or by letter, and mail direct to Commander, US Army Troop Support Command, ATTN: AMSTS-MPP, 4300 Goodfellow Boulevard St. Louis, MO 63120. A reply will be furnished direct to you.

Page 2-1. Paragraph 2-5, subparagraph d is added as follows:

d. *Grounding Procedure.*

**CAUTION**

Generator set should be grounded in order to prevent shock due to defective insulation or external electrical faults. Poor grounding can endanger personnel, may damage equipment, and

can create interference in communication or electronic circuits.

(1) Install one of the following items as grounding device:

(a) Drive a ground rod to depth of at least 8 feet. This is the preferred device which is available in the Army Supply System.

(b) Drive a ground pipe, 3/4 inch, copper or steel, to a depth of at least 8 feet. An existing under ground pipe may be used in an emergency.

(c) Bury a 1/4 inch thick iron or steel plate, approximately 18 inch x 18 inch size with ground cable attached, to a depth of at least 4 feet.

(d) Bury a 1/16 inch thick aluminum or copper plate, approximately 18 inch x 18 inch size, with ground cable attached, to a depth of at least 4 feet.

(2) Saturate the area around the grounding device with water to increase conductivity.

(3) Connect the ground cable from the grounding device to the generator set frame ground terminal (fig 1-4) and tighten the nut securely.

**NOTE**

**Ground cables should be copper. Braided cable is the best, but No. 6 AWG gauge (or larger) copper wire will suffice.**

Page A-1. Paragraph A-1 is superseded as follows:

**A-1. Fire Protection and Safety**

TB 5-4200-200-10  
TB MED 25

Hand portable fire extinguishers approved for army users.  
Noise and conservation of Hearing.

By Order of the Secretary of the Army:

FRED C. WEYAND  
General, United States Army  
Chief of Staff

Official:

VERNE L. BOWERS  
Major General, United States Army  
The Adjutant General

Distribution:

To be distributed in accordance with DA Form 12-25D (qty rqr block No. 650) Organizational maintenance requirements for Generator Set-Engine Driven .125KW.

Changes In force: C 1 and C 2

Change  
No. 2

HEADQUARTERS  
DEPARTMENT OF THE ARMY  
Washington, D.C., 16 January 1973

**Operator's, Organizational, Direct Support,  
General Support and Depot Maintenance Manual  
Including Repair Parts and Special Tools Lists  
GENERATOR SET, GASOLINE ENGINE:  
0.125 KW, AC, 115 V, SINGLE PHASE,  
400 HERTZ; SPECIAL PURPOSE;  
PORTABLE; W/CARRYING CASE  
(HOMELITE MODEL XLA 115/1/400-1P)  
FSN 6115.930-9498**

TM 5-6115-405-15, 11 July 1967, is changed as follows:

The cover and title page are changed as shown above.

Page 2-1, paragraph 2-3. Subparagraph is added as follows:

f. Maintenance and operating supplies required for the initial 8 hours of operation of the generator set are contained in table 2-1.

**Table 2-1. Maintenance and Operating Supplies**

(1) Component application	(2) Federal stock number	(3) Description	(4) Quantity required for initial operation	(5) Quantity required for 8hrs operation	(6) Notes
0306—FUELTANK (Note)	9131-160-1818	FUEL, GASOLINE: Bulk as follows: Automotive, Combat 91A	18 ounces		Tank capacity average fuel consumption is 1/10 gal per hour of continuous operation.

**APPENDIX B  
BASIC ISSUE ITEM LIST AND ITEMS TROOP INSTALLED OR AUTHORIZED**

**Section I. Introduction**

**B-1. Scope**

This appendix lists items troop installed or authorized which accompany the generator set, and which are required by the crew/operator for operation, installation, and operator's maintenance.

**B-2. General**

This list is divided into the following sections:

a. Basic Issue Items List-Section II. Not applicable.

b. *Items Troop Installed or Authorized List* Section III. A list in alphabetical sequence of items which, at the discretion of the unit commander, may accompany the end item. but are not subject to be turned in with the end item.

**B-3. Explanation of Columns**

The following provides an explanation of columns in the tabular list of items troop installed or authorized, section III.

a. *Source, Maintenance, and Recoverability Code (s) (SMR)*: Not applicable.

b. *Federal Stock Number*. This column indicates the Federal stock number assigned to the item and will be used for requisitioning purposes.

c. *Description*. This column indicates the Federal item name and any additional description of the item required.

d. *Unit of Measure (U/M)*. A 2-character alphabetic abbreviation indicating the amount or quantity of the item upon which the allowances are based: e.g., for each.

e. *Quantity Authorized*. This column indicates the quantity of the item authorized to be used with the equipment.

**Section III. ITEMS TROOP INSTALLED OR AUTHORIZED LIST**

(1) Smr Code	(2) Federal stock no.	(3) Description  Ref. No. & Mfr Code	(4) Unit of meas	(5) Qty auth
	7520-559-9618 2990-978-7302 3975-878-3791	CASE, MANUAL ROPE, STARTING ROD, GROUND ASSEMBLY	ea ea ea	1 1 1

By Order of the Secretary of the Army:

Official:

VERNE L. BOWERS  
*Major General, United States Army*  
*The Adjutant General*

CREIGHTON W. ABRAMS  
*General, United States Army*  
*Chief of Staff*

Distribution:

To be distributed in accordance with DA Form 12-25D (qty rqr block No. 650), Organizational Maintenance Requirements for Generator Sets, Engine Driven. .125 KW.

CHANGE }  
No. 1 }

HEADQUARTERS  
DEPARTMENT OF THE ARMY  
WASHINGTON, D.C., 15 February 1968

**Operator, Organizational, Direct Support, and  
General Support, and Depot Maintenance Manual  
Including Repair Parts and Special Tools List**

**GENERATOR SET, GASOLINE ENGINE: 0.125 KW, AC, 115V,  
SINGLE PHASE, 400 CYCLE; SPECIAL PURPOSE; PORTABLE;  
W/CARRYING CASE (HOMELITE MODEL XLA115/1/400-1P)  
SERIAL NUMBERS 2,330, 386 THROUGH 2,331,917  
FSN 6115-930-9498**

TM 5-6115-405-15, 11 July 1967, is changed as follows:

The cover and title page is changed as shown above.

*Inside Cover Page, Safety Precautions.* Add the following:

Pressure relief valve in front side of carrying case to be opened before airflight-closed after airflight.

*Page 1-1.* Paragraph 1-1d is superseded as follows:

d. Report of errors, omissions, and recommendations for improving this publication by the individual user is encouraged. Reports should be submitted on DA Form 2028 (Recommended Changes to DA Publications) and forwarded direct to the Commanding General, U. S. Army Mobility Equipment Command, ATTN: AMSMEMPP, 4300 Goodfellow Boulevard, St. Louis, Mo. 63120.

Paragraph 1-3b. "OE-30 oil (FSN 9150-2659433)" is changed to read "SAE-30 non-detergent oil FSN 9150-753-4937, MIL-L-22851."

*Page 2-2.* Immediately after paragraph 2-6b add the following:

**Caution**  
**Pressure relief valve in front side of  
carrying case to be opened before  
airflight closed after airflight.**

*Page 2-5.* Paragraph 2-16f is added after paragraph 2-16e.

f. Clean the governor linkage assembly at carburetor chamber and governor assembly at each fuel servicing or more frequently if required. Clean a small paint brush or cloth dampened with an approved cleaning solvent and blowing all loose dust from the carburetor chamber.



Page 3-3. Figure 3 2. After item 1 add item 1A.  
 1A *Carburetor Chamber*. Clean at each fuel servicing or as required (para ref. 3-7).

Figure 3-2. After item 7 add item 7A.

7A *Governor Linkage*. Clean at each fuel servicing if required and not to exceed 50 hours (para ref. 3-12).

Page 3-4. Paragraph 3-7d is added after paragraph 3-7c.

d. Remove air cleaner element as shown in figure 3-3. Using long bristle paint brush or cloth, clean and blow the dust and dirt from the carburetor chamber at each fuel servicing if required, and not to exceed 50 hours.

Page 3-7. Paragraph 3-12e is added after paragraph 3-12d.

e. When operating in a dusty area, clean the accumulated dirt and dust from the governor linkage (fig. 3-5) using a small paint brush or cloth and blowing at each fuel servicing if required, and not to exceed 50 hours.

Paragraph 3-14. Add the following:

<i>Probable Cause</i>	<i>Possible Remedy</i>
Carburetor chamber clogged	Clean chamber, paragraph 3-7.
Governor linkage clogged	Clean linkage, paragraph 3-12.

Page 5-1. Paragraph 5-1. (Delete) "No special tools and equipment are required", add "Special tools are required".

Page 6-12. Paragraph 6-15j is added after paragraph 6-15i.

j. Inspect the spark plug port in the cylinder head for stripped or damaged threads. Repair as follows:

(1) *Ream and retap*. (A, fig. 6-6).

(a) Ream and retap spark plug port using the 14MM piloted reamer tap (P/N 1030-14) from repair kit FSN 5180-935-4600 by engaging the pilot thread in the existing tapped hole.

**Caution**

**Smear the piloted reamer tap with heavy grease before tapping to prevent chips from entering the combustion chamber.**

(b) Complete the reaming and retapping operation.

**Note**

**The special threaded pilot on the tap pulls reamer and tap through the original threads, thus assuring precision thread alinement.**

(c) Remove chips and clean port threads and cylinder thoroughly.

(2) *Install insert*. (B, fig. 6-6).

(a) Firmly seat a helical coil insert, mfg. code 26014 (P/N 137-43) from insert packet (P/N 4196-43) using inserting tool (PN/4971-14) contained in kit FSN 5180 935 4600 into the tapped threads of the spark plug hole.

(b) The serrated or top end of the insert coil should be 1 to 1 1/4 pitch below the top surface of the hole.

**Note**

**No portion of the insert should enter the combustion chamber.**

(c) Break off driving tang with a pair of long-nosed pliers. Grasp the tang near the notch, with a back and forth motion, being careful not to remove the last coil of the insert from the tapped thread. Discard tang.

**Caution**

**Do not let tang fall into combustion chamber.**

Page 6-15. Figure 6-6 is added after page 6-15.



A. REAMING AND RETAPPING



B. INSTALLING INSERT

6115-405-15/6-6

**Figure 6-6. Repair of spark plug port.**

Page B-2. Section II, Basic Issue Items List, is superseded as follows:

(1) Source Maint. & Recov. code			(2)	(3)	(4)	(5)	(6)	(7)	(8)	
(A)	(B)	(C)	Federal Stock No.	Description	Unit of Issue	Qty. Inc in Unit Pack	Qty. Inc in Unit	Qty. Auth	Illustration	
S	M	R							(A) Fig. No.	(B) Item or Sym No.
				GROUP 31-BASIC ISSUE ITEMS MANUFACTURER INSTALLED						
P	O		7510-889-3494	3100-Basic Issue Items Manufacturer or Depot Installed						
P	O		7520-559-9618	BINDER: equipment log book	EA	1	*	1		
				CASE: maintenance and operational manuals; cotton duck, water repellent, mildew- resistant	EA	1	1	1		
				DEPARTMENT OF THE ARMY: operator, organiza- tional, direct and general support and depot main- tenance manual including repair parts and special tools list, TM 5-6115-405-15	EA	1	1	1		
P	O		4720-977-1078	LINE, FUEL, AUXILIARY (29201) 62704	EA	1	1	1		
				GROUP 32-BASIC ISSUE ITEMS, TROOP INSTALLED						
				3200-Basic Issue Items, Troop Installed or Authorized						
P	O		5110-595-8595	FILE: contact point 3200-Basic Issue Items, Troop Installed or Authorized (continued)	EA	1	1	1		
P	O		5210-189-9538	GAGE: gap settings, sparkplug	EA	1	1	1		
P	O		5120-223-7396	PLIERS: slip joint, straight nose w/cutter 6 in. length	EA	1	1	1		
P	O		5120-293-3169	SCREWDRIVER: flat tip, tip 5/16" wide, blade 6" length	EA	1	1	1		
P	O		5120-240-5328	WRENCH: open end; adjustable 15/16" jaw opening 8" length	EA	1	1	1		
P	O		5120-945-4704	WRENCH: sparkplug	EA	1	1	1		

Page B-4. Item 1. Column 4 (added) FSN 9150753-4937.

Item 1. Column 5 is changed to read "Oil Lubrication, 5 gal pail as follows SAF-30 Non-detergent oil (MIL-L22851)".

Item 1. Column 8. Delete "See LO 5-6115405-15 for grade application and replenishment interval."

Page C-2. Group 0100. Line 1, change column M to read "A-B".

Page C-3. Group 0102. Line 1, column I, add "F".

Group 0102. Line 1, column L, add "L-I".

Group 0102. Line 1, column M, add "C-I".

Group 04. Under Group 04 add "0401"

Group 0401. Line 2, change column M to read "B-C".

Page C-4. Section III. Special tool and Special Test Equipment Requirements. (Delete) "No special tool or special test equipment required", and add the following:

Reference code column, add: "L".

Maintenance level column, add: "F".

Nomenclature column, add: "Spark Plug Port Repair Kit."

Tool number column, add: "FSN 5180-935-4600."

Section IV. Remarks.

Reference code column, add: "C-I".

Remarks column, add: Repair spark plug port threads.

Page D4. Item 1. Column (3) (a), change "2" to read "5".

Item 9. Column (3) (a), change "\*" to read "5".

PAGE	LINE	ACTION	(1) SOURCE, MAINT AND RECOV CODE			(2)  FEDERAL STOCK NUMBER	(3)  DESCRIPTION	(4) UNIT OF ISSUE	(5) QTY INC IN UNIT PACK	(6) QTY INC IN UNIT	(7) 15 DAY ORG. MAINT. ALW				(8) ILLUS- TRATION	
			(A)	(B)	(C)						(A)	(B)	(C)	(D)	(A)	(B)
			S	M	R						1-5	6-20	21- 50	51-100	FIG NO.	ITEM OR SYM NO.
D6	0144					Immediately after VALUE (29201) 56865-1, add the following line item.										
D6	0144 A	Add	P	O	2910-977-1083	ELEMENT, FELT, FILTER	EA		1	2	3	6	13			
D8	0271	Change col (1) (a), add col (7) (a), (b) and (c)	P													

PAGE	LINE	ACTION	(1) SOURCE, MAINT AND RECOV CODE			(2)  FEDERAL STOCK NUMBER	(3)  DESCRIPTION	(4) UNIT OF ISSUE	(5) QTY INC IN UNIT PACK	(6) QTY INC IN UNIT	(7) 30-DAY DS/GS MAINT. ALW.			(8)  1 YR ALW PER 100 EQUIP  CTYGCY  PLANN- ING	(9)  DEPOT MAINT ALW PER 100 EQUIP	(10) ILLUS- TRATION	
			(A)	(B)	(C)						(A)	(B)					
			S	M	R								1-20			21-50	51-100
D9	0013					Immediately after STUD (29201) 56470-1, add the follow- ing line item											
D9	0013 A	Add	P	F		INSERT KIT	PK	30	1	*	2	2	12	4			
D13	0144					Immediate after VALVE (29201) 56865-1, add the follow- ing line item											
D13	0144 A	Add	P	O	2910-977-1083	ELEMENT, FELT, FILTER	EA		1	6	13	25	300				
D17	0271	Change col (1) (a), add col (7) (a), (b), and (c)	P							*	*	*					
D17	0271	Add col (8)											5				

By Order of the Secretary of the Army:

Official:

KENNETH G. WICKHAM,  
*Major General, United States Army,  
The Adjutant General.*

HAROLD K. JOHNSON  
*General, United States Army,  
Chief of Staff.*

Distribution:

To be distributed in accordance with DA Form 12-25, Section IV, Organizational Maintenance requirements for Electrical Generating Equipment Generator Sets, Engine Driven, .125 KW.



**Operational, Organizational, Direct And General Support  
And Depot Maintenance Manual Including Repair Parts  
GENERATOR SET, GASOLINE ENGINE: 0.125 KW, AC,  
115 V, SINGLE PHASE, 400 CYCLE; SPECIAL PURPOSE;  
PORTABLE; W/CARRYING CASE (HOMELITE MODEL  
XLA115/1/400-1P) SERIAL NUMBERS 2,330,386  
THROUGH 2,331,917, FSN 6115-930-9498**

		Paragraph	Page
CHAPTER	1. INTRODUCTION		
Section	I. General .....	1-1, 1-2	1-1
	II. Description and tabulated data .....	1-3 - 1-5	1-1 - 1-3
CHAPTER	2. INSTALLATION AND OPERATION INSTRUCTIONS		
Section	I. Service upon receipt of equipment .....	2-1 - 2-5	2-1
	II. Movement to new worksite .....	2-6, 2-7	2-2
	III. Controls and instruments .....	2-8, 2-9	2-2
	IV. Operation of equipment .....	2-10 - 2-19	2-4, 2-5
CHAPTER	3. OPERATOR AND ORGANIZATIONAL MAINTENANCE INSTRUCTIONS		
Section	I. Special tools and equipment .....	3-1, 3-2	3-1
	II. Preventive maintenance services .....	3-3 - 3-5	3-1, 3-2
	III. Operator's maintenance .....	3-6 - 3-12	3-4, 3-5
	IV. Troubleshooting .....	3-13 - 3-17	3-7, 3-8
	V. Radio interference suppression .....	3-18 - 3-21	3-8
	VI. Carburetor .....	3-22, 3-23	3-8
CHAPTER	4. DIRECT AND GENERAL SUPPORT AND DEPOT MAINTENANCE INSTRUCTIONS		
Section	I. General .....	4-1, 4-2	4-1
	II. Description and tabulated data .....	4-3, 4-4	4-1
CHAPTER	5. GENERAL MAINTENANCE INSTRUCTIONS		
Section	I. Special tools and equipment .....	5-1, 5-2	5-1
	II. Troubleshooting .....	5-3 - 5-6	5-9
	III. Radio interference suppression .....	5-7 - 5-9	5-9
	IV. Removal and installation of major components .....	5-10 - 5-14	5-10 - 5-15
CHAPTER	6. SPECIFIC REPAIR INSTRUCTIONS		
Section	I. Starter fan housing and ignition parts .....	6-1 - 6-4	6-1
	II. Generator .....	6-5 - 6-8	6-4
	III. Carburetor chamber .....	6-9 - 6-12	6-7
	IV. Engine .....	6-13 - 6-16	6-12
	V. Carburetor assembly .....	6-17 - 6-20	6-13 - 16-5
APPENDIX	A. REFERENCES .....		A-1
	B. BASIC ISSUE ITEMS LIST AND MAINTENANCE AND OPERATING SUPPLIES .....		B-1
	C. MAINTENANCE ALLIACATION CHART .....		C-1
	D. ORGANIZATIONAL, DIRECT, AND GENERAL SUPPORT AND DEPOT MAINTENANCE REPAIR PARTS LIST .....		D-1
INDEX	.....		I-1

## CHAPTER 1

### INTRODUCTION

---

#### Section I. GENERAL

##### 1-1. Scope

a. These instructions are published for use by personnel to whom the Homelite Model XLA115/1/400-1P generator set is issued. Chapters 1 through 3 provide information on operation, preventive maintenance services, and organizational maintenance of equipment, accessories, components, and attachments. Chapters 4 through 6 provide information for direct and general support and depot maintenance. Also, included are descriptions of main units and their functions in relationship to other components.

b. Appendix A contains a list of publications applicable to this manual. Appendix B contains the list of basic issue items authorized the operator of this equipment, and the list of maintenance and operating supplies required for initial operation. Appendix C contains the maintenance allocation chart. Organizational, direct and general support repair parts and special tools are listed in appendix D.

c. Numbers in parenthesis following nomenclature callouts on illustrations indicate quantity; numbers preceding nomenclature callouts indicate preferred sequence.

d. DA Form 2028 (Recommended Changes to DA Publication) will be used for reporting discrepancies and recommendations for improving this equipment publication. This form will be completed by the individual using the manual and forwarded direct to Commanding General, U. S. Army Mobility Equipment Command, ATTN: AMSME-MPD, 4300 Goodfellow Blvd., St. Louis, Mo. 63120.

##### 1-2. Record and Report Forms

a. DA Form 2258 (Depreservation Guide for Vehicles and Equipment).

b. For other record and report forms applicable to operator, crew, and organizational maintenance, refer to TM 38-750.

##### Note

**Applicable forms, excluding Standard Form 46 (United States Government Motor Vehicle Operator's identification card) which is carried by the operator, shall be kept in the publications case mounted in the carrying case cover.**

#### Section II. DESCRIPTION AND TABULATED DATA

##### 1-3. Description

a. *General.* The Homelite Model XLA115/1/400-IP generator set (figs. 1-1 and 1-2) is a gasoline operated lightweight, hand-portable, self-contained generator set that produces 125-watt, 400-cycle, single-phase, 115volt, ac (alternating current) power.

b. *Engine.* The engine is a single-cylinder, two-stroke-cycle unit that operates on a mixture of motor oil and gasoline in the ratio of 1 part OE-30 oil (FSN 9150-

265-9433) to 32 parts gasoline. The starter is of the recoil type. The engine speed is regulated to 4000 rpm by means of a centrifugal governor which controls the throttle.

c. *Generator.* The generator is of the permanent magnet type. The stator is secured to the main frame, and the permanent magnet rotor is keyed to a shaft which is in turn screwed onto the engine crankshaft with a left-hand thread.



The output is taken from the stator and wired directly to the output connector. The output is 12.5 watts at unity power factor.

d. *Carrying Case.* The entire generator set and the included accessories are provided with a specially designed molded plastic carrying case (fig. 1-3) for transportation and storage. The upper half of the case has a carrying handle on top and a storage area for the publications case which is secured by a spring clip. An air valve is provided to equalize inside and outside air pressures. (See instructions on carrying case.) The upper half of the case is secured to the lower half by four latches. An accessory bag is placed in the lower portion of the case.

**1-4. Identification and Tabulated Data**

a. *Identification.* The Homelite Model XLA11/1/400-1P generator set has two major identification plates One is located on the carrying case and the other is located on the starter fan housing. The information contained on the two plates is listed below and is identical except the serial number is not included on the carrying case identification plate.

- Generator set
- 0.125 KW
- 115 V
- 1 PH
- 100 CYC
- 1.0 PF
- 2 WIRE
- 4000 RPM
- Fuel: Gasoline -- Oil mixed
- Model No. XLA11/1/400-1P
- Contract No. DA23-195-AMC-00763(T)
- FSN 611930-9498

b. *Tabulated Data.*

(1) *Generation, set.*

Manufacturer.....Homelite  
 Model.....XLA15/1/400-1P

(2) *Engine.*

Manufacturer.....Homelite  
 Type.....Air-cooled  
 Number of cylinders ..... 1  
 Stroke cycle ..... 2  
 Fuel ..... Gasoline and oil mixed

Fuel tank capacity ..... 18 oz liquid  
 Piston displacement ..... 3.3 cu in.  
 Bore ..... 1 3/4 in.  
 Stroke ..... 1 3/8 in.  
 Compression ratio ..... 8:1  
 Air cleaner..... Dry type  
 Ignition system ..... Magneto  
 Type of lubrication..... Oil mixed with fuel  
 Governor..... Mechanical-centrifugal type

(3) *Generator.*

Manufacturer.....Homelite  
 Type.....Permanent magnet  
 Rated speed..... 4000 rpm  
 Drive ..... Direct  
 Phase..... Single  
 Output power ..... 125 watts  
 Output voltage ..... 115 volts, 400 cps  
 Power factor..... 1.0

(4) *Engine accessories.*

(a) *Carburetor.*

Manufacturer.....Tillotson  
 Model.....HS40A  
 Type.....Diaphragm with integral fuel pump

(b) *Ignition System.*

Type.....Magneto  
 Manufacturer of magneto ..... Wico  
 Model.....FW-2782-C  
 Manufacturer of high ..... Hallet  
 tension lead.  
 Type.....Shielded

(c) *Spark plug.*

Manufacturer.....Champion  
 Type.....XEJ-12 with integral suppresser  
 Size ..... 14 mm

(5) *Adjustment data.*

Spark plug gap..... 0.030 in.  
 Magneto breaker point gap ..... 0.015 in.

(6) *Torque data.*

Spark plug..... .250-300 in lb  
 No. 8 spinlock screws..... 36 in. lb min  
 No. 10 spinlock screws..... 50 in. lb min  
 No. 12 spinlock screws..... 80 in. lb min  
 No. 4-40 ordinary screws..... 4-3/4 in. lb min  
 No. 6-32 ordinary ..... 8-3/4 in. lb min screws.  
 No. 832 ordinary..... 18 in. lb min screws.  
 No. 10-24 ordinary ..... 23 in. lb min screws.  
 No. 10-32 ordinary ..... 32 in. lb min screws.

(7) *Dimensions and weight.*

(a) *Generator less carrying case.*

Length..... 11 3/4 in.  
 Width..... 12 3/16 in.  
 Height..... 11 3/4 in.  
 Weight..... 22 1/2 lb

(b) *Carrying case.*

Length..... 15 5/16 in.  
 Width..... 14 5/16 in.  
 Height..... 13 1/4 in.  
 Weight..... 7 lb

(c) *Shipping dimensions.*

1. *Cardboard carton (B/B level)*

length..... 15 in.  
 Width..... 14 3/4 in.  
 Height..... 13 3/4 in.

Volume ..... 3042 cu in.  
 Weight ..... 2 1/2 lb

2. *Plywood case (A/A level)*

Length..... 17 in.  
 Width..... 16 3/4 in.  
 Height..... 16 3/4 in.  
 Volume ..... 4485 cu in.  
 Weight ..... 18 lb

(8) *Wiring diagram.* (fig. 1-4)

(9) *Base plan.* (fig. 1-5)

**1-5. Differences in Models**

This manual covers only the Homelite Model XLA115/1/400-IP generator set. No known unit differences exist for the model covered by this manual.

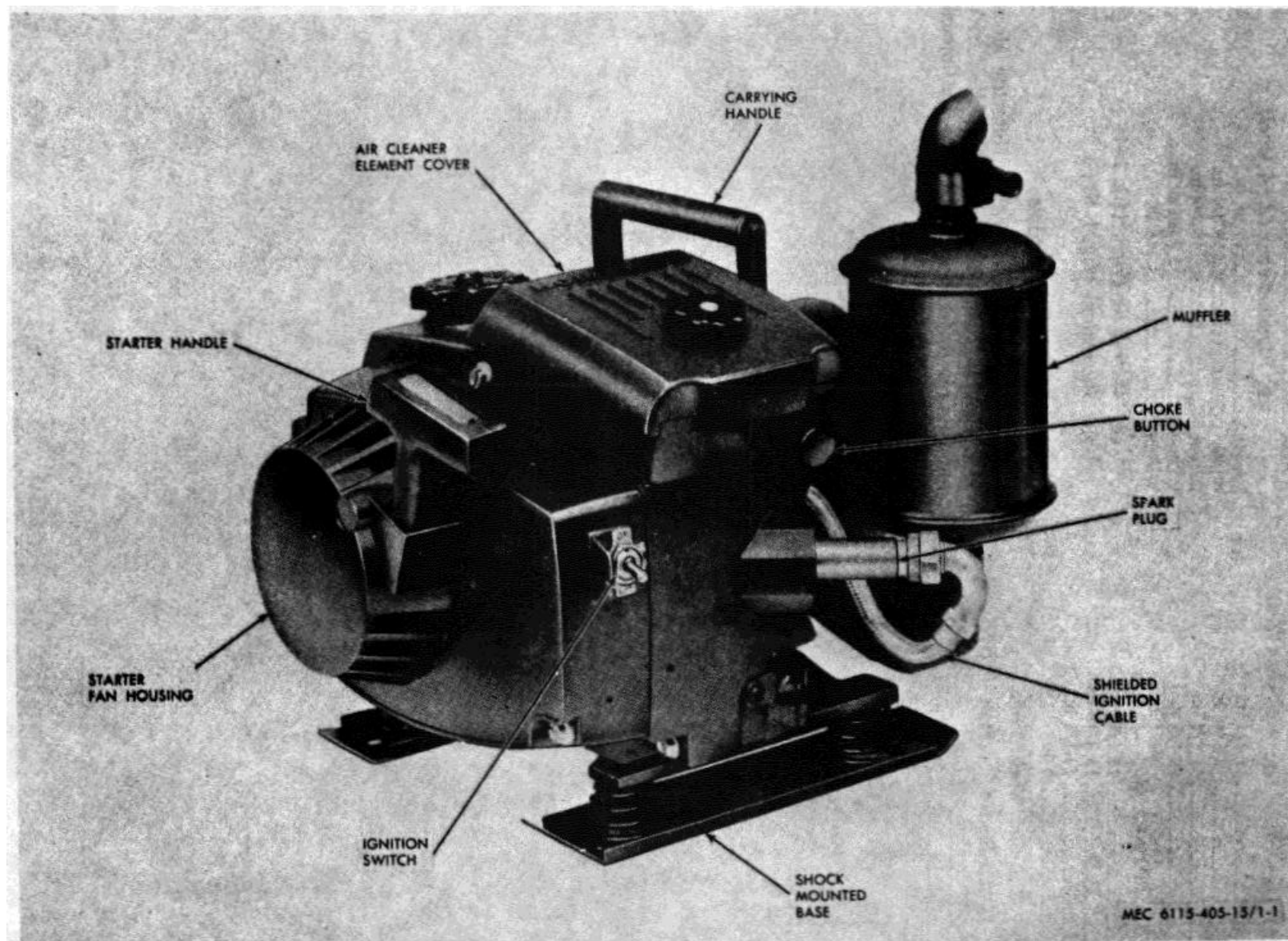

Figure 1-1. Generator set, left-front, three-quarter view.

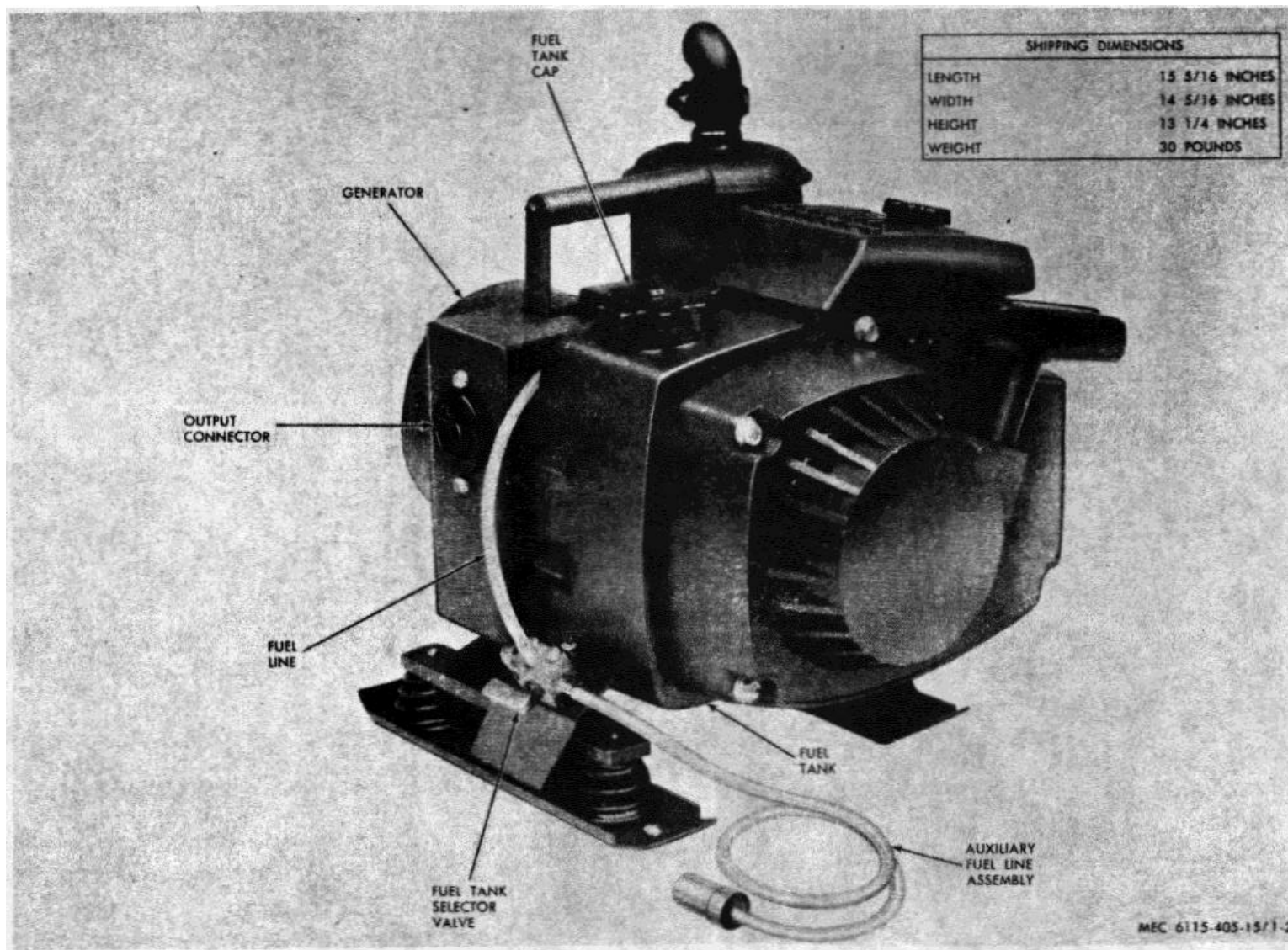

Figure 1-2. Generator set, left-rear, three-quarter view.

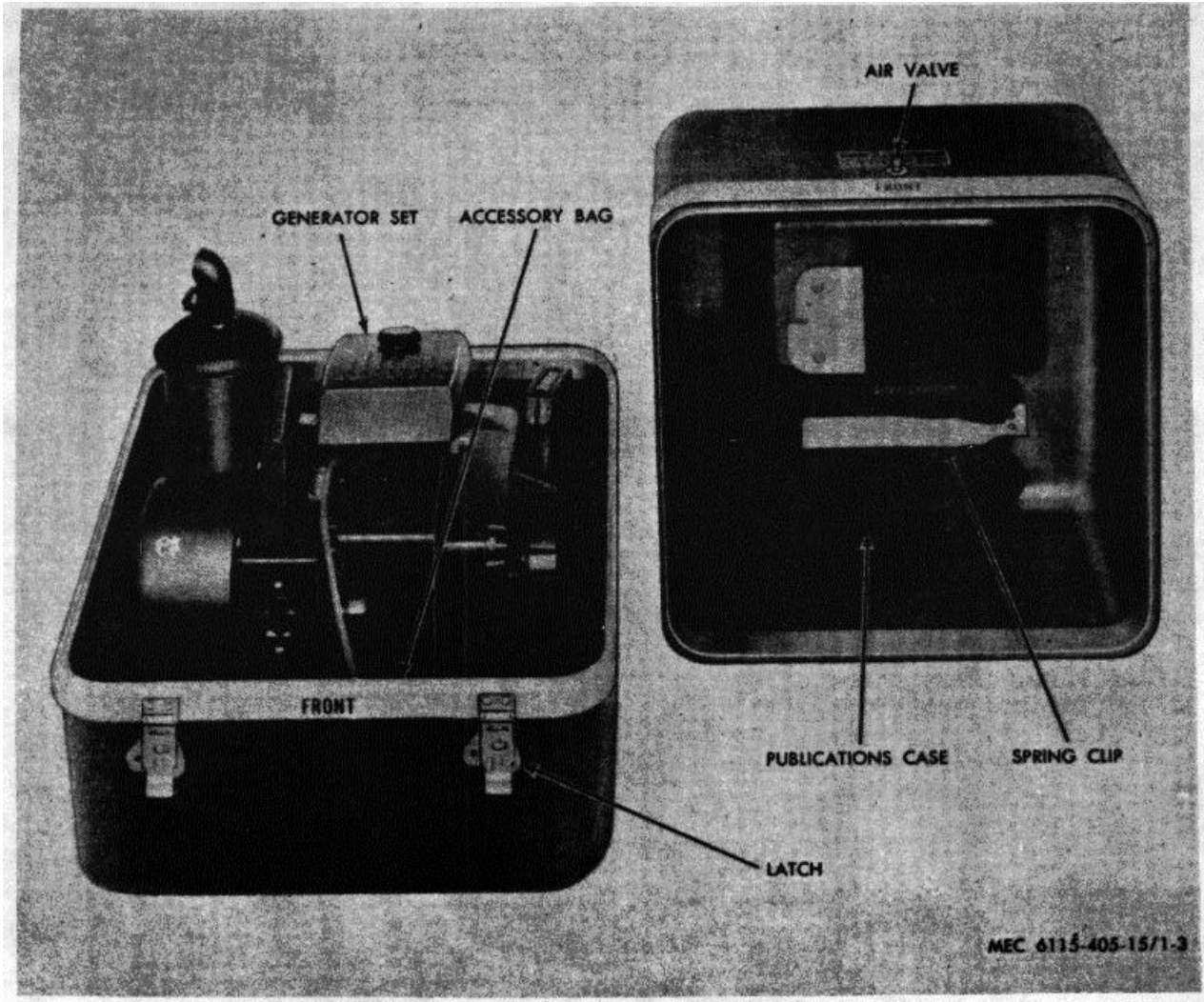

Figure 1-3. Generator set in carrying case.

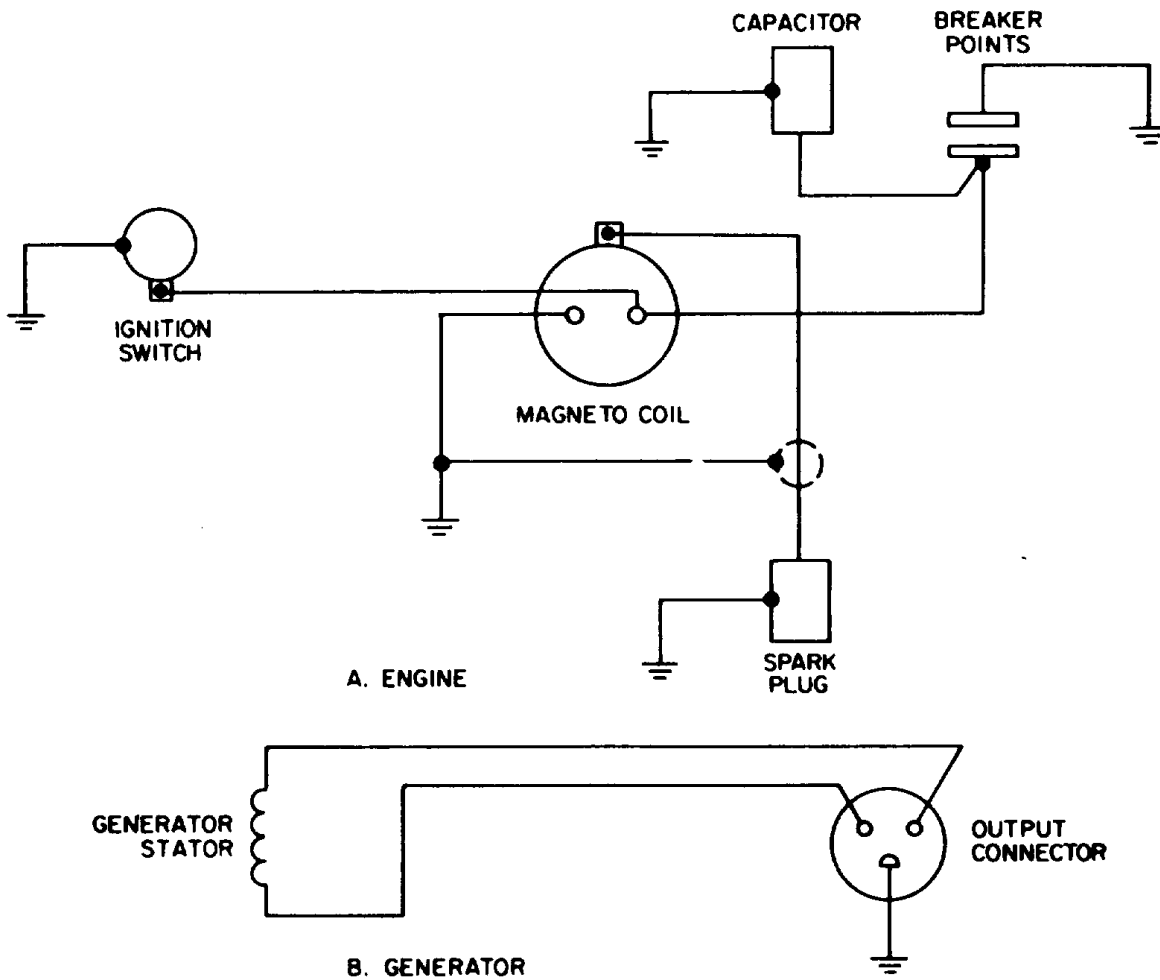
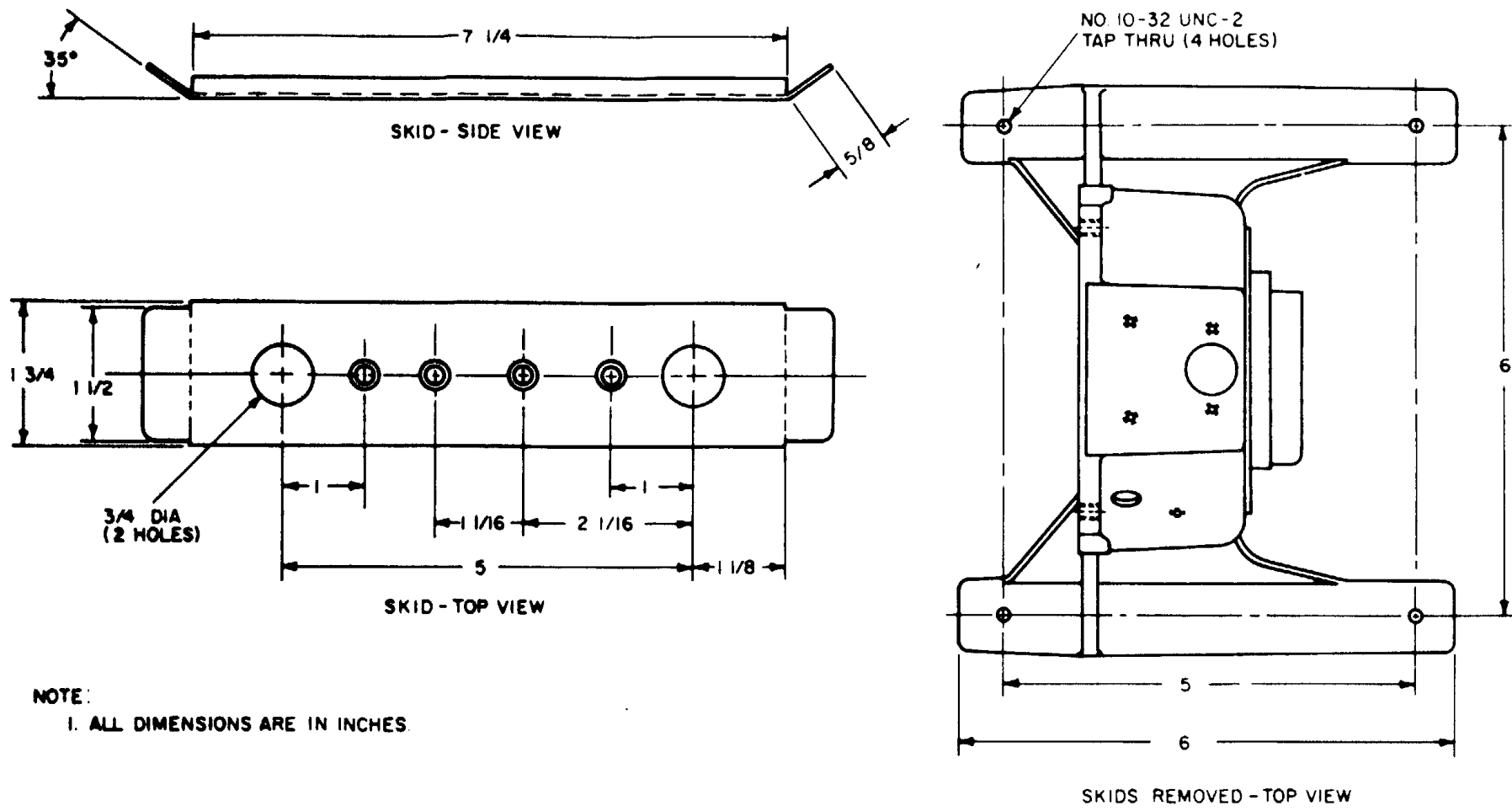

Figure 1-4. Practical wiring diagram

MEC 6115-405-15/1-4



NOTE:  
1. ALL DIMENSIONS ARE IN INCHES

Figure 1-5. Base plan

## CHAPTER 2

## INSTALLATION AND OPERATION INSTRUCTIONS

## Section I. SERVICE UPON RECEIPT OF EQUIPMENT

**2-1. Unloading Equipment**

The generator set as shipped in its carrying case needs no special unloading instructions. Observe normal handling procedures and do not drop or throw the shipping container from or into vehicles.

**2-2. Unpacking Equipment**

*a. Removal from shipping container.* Remove the banding from the exterior shipping container. Using the carrying case handle, lift the generator set and carrying case from the shipping container.

*b. Removal from carrying case.*

- (1) Open the air valve to equalize the pressure inside and outside the carrying case.
- (2) Lift each latch key to its upright position, and rotate 1/2 turn counterclockwise to free the latch from the upper portion metal rim of the carrying case.
- (3) Using the carrying case handle, lift the cover straight off the lower portion.
- (4) Using the generator set carrying handle, lift the generator set out of the case.

**2-3. Inspecting and Servicing Equipment**

*a.* Remove the publications case from the cover of the carrying case. Remove the accessory bag from the lower portion of the case. Refer to the basic issue items list (app. B) to check for the presence of all required materials.

*b.* Visually check the generator set for missing parts and for damage that may have occurred during shipment. Check for damaged muffler, spark plug, fuel tank selector valve, and ignition cable. (fig. 1-1.)

*c.* Check all parts for insecure mounting. Tighten all loose mounting screws and caps.

*d.* Grasp the starter handle (fig. 1-1) and pull it slowly to check for free rotation of the engine. Listen for any unusual noises which may be caused by damaged engine components or by loose or rubbing generator rotor.

*e.* Refer to paragraph 3-4 for daily preventive maintenance services to be performed.

**2-4. Installation of Separately Packed Components**

Since the generator set is shipped completely assembled, no installation is required. Parts shipped in the accessory bag are spares.

**2-5. Installation or Setting-Up Instructions**

*a. Location.* Position the generator set on a hard, level, non-flammable surface. If possible, provide shelter for operation during inclement weather. Position the generator set to allow adequate air circulation and make sure that the exhaust fumes are directed away from operating personnel.

**Caution:**

**Never operate the generator set without removing it completely from the carrying case. Operation while the unit is installed in the bottom half of the carrying case will restrict air circulation and cause overheating.**

*b. Indoor installation.* If the generator set is to be installed indoors, the exhaust must be vented to the outside of the building. Make sure all exhaust connections are tight and that the room is well ventilated. Provide adequate air ventilation around the generator set to prevent overheating. Observe the additional requirements of a above.



**Warning:**

**Do not operate the generator set in an enclosed area unless exhaust gases are piped to the outside. Inhalation of exhaust fumes will result in serious illness or death.**

*c. Fueling procedure.*

**Note.**

The generator set is provided with a three position fuel tank selector valve (fig. 1-2) When the valve handle is positioned to the left, the integral fuel tank is connected. When the valve handle is positioned to the right, and external fuel tank can be used for extended operation. The external tank will have to be annotated to the nipple on the right side of the selector valve. During fueling, keep the fuel tank selector valve handle in the left (integral tank) position. If the handle is set to the upright (vertical) position, fuel will be discharged through the external access port.

- (1) *Fuel preparation.* Using a clean container, accurately measure and mix together one part of SAE 30 motor oil and

32 parts of clean, fresh, regular grade gasoline. This ratio is 1/4 pint (4 oz.) of oil per gallon (128 oz.) of gasoline. Shake or stir the mixture thoroughly to insure uniform distribution. Since the generator set depends entirely on the fuel mixture for lubrication, it is very important that the mixture is uniform.

**Caution:**

**Always use a separate container to prepare the fuel. Never mix the fuel in the generator set fuel tank. An improperly prepared mixture may cause engine damage due to lack of proper lubrication.**

- (2) *Adding fuel to tank.* Be sure ignition switch is set to OFF. Remove the fuel tank cap and carefully pour the oil-fuel mixture into the fuel tank. Do not fill to the top of the tank. Leave a little air space to allow for fuel expansion.

**Warning:**

**Wipe up any spilled fuel immediately. Keep the generator set clean and dry.**

**Section II. MOVEMENT TO NEW WORKSITE**

**2-6. Dismantling for Movement**

a. If the generator set is to be hand-carried or transported by truck for short distances, it is permissible to move the equipment while fuel remains in the tank. Position the fuel tank selector valve handle to the left. Remove the external fuel line from the auxiliary fuel tank and protect the filter on the end of the line from contamination by wrapping in clean cloth or paper. Make sure the fuel tank cap is securely tightened. Place the generator set and the external fuel line in the carrying case and close the latches.

**Note.**

**Make sure to include the accessory bag and related documents in the carrying case.**

b. If the generator set is to be transported, drain fuel tank before shipment. Remove fuel cap and turn the generator set upside down. For complete drainage of fuel lines, turn generator set upright and run unit until it stops.

**2-7. Reinstallation After Movement**

Refer to paragraph 2-5 for reinstallation procedures.

**Section III. CONTROLS AND INSTRUMENTS**

**2-8. General**

This section describes, locates, illustrates, and furnishes operator, crew, or organizational maintenance personnel sufficient information about various controls and instruments for proper operation of the generator set;

**2-9. Controls and Instruments**

The purpose of controls and instruments is illustrated in figure 21.

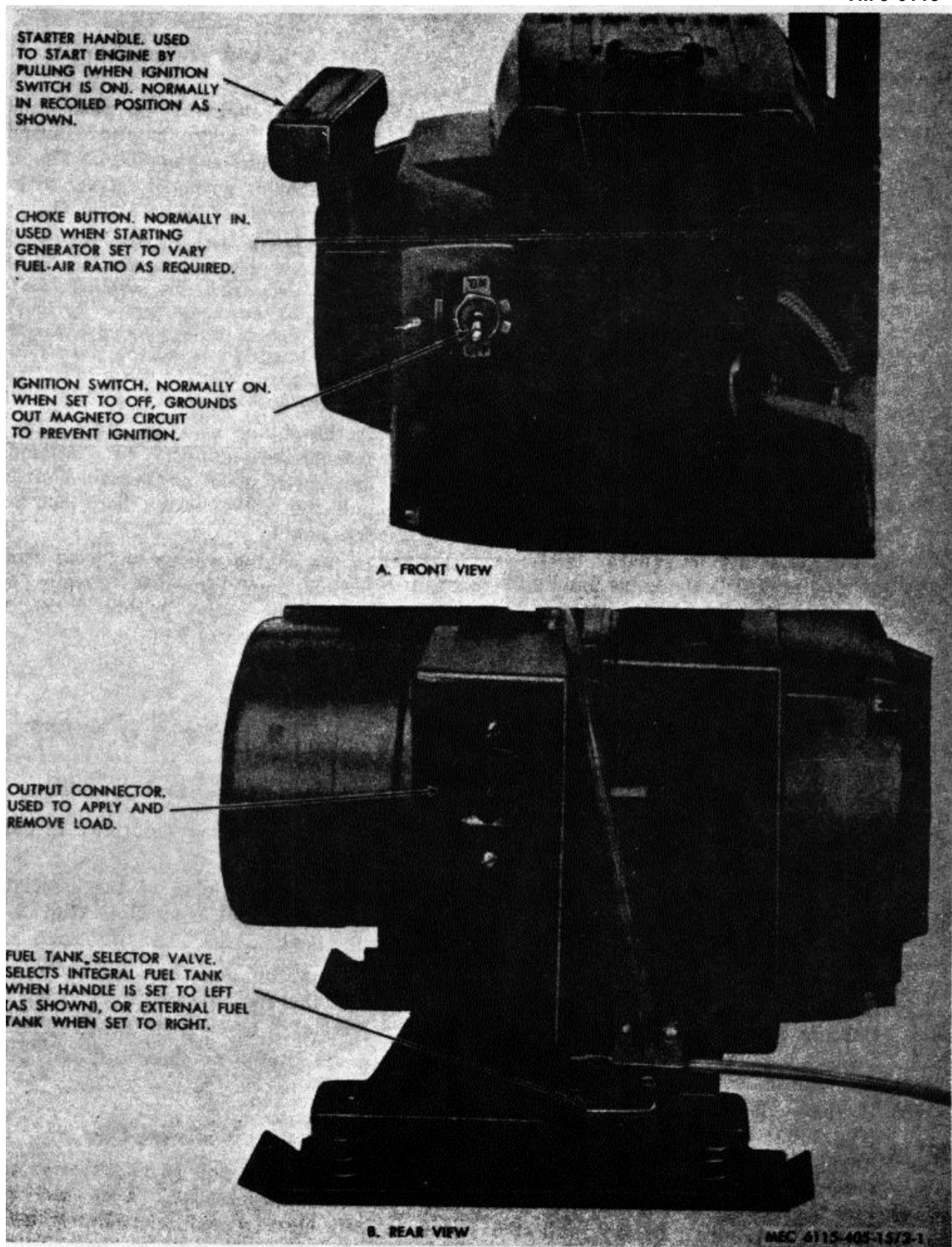

Figure 2-1. Controls and instruments.

## Section IV. OPERATION OF EQUIPMENT

### 2-10. General

a. Instructions in this section are published for information and guidance of personnel responsible for operation of the generator set.

b. The operator must know how to perform every operation of which the generator set is capable. This section gives instructions on starting and stopping the generator set, basic motions of the generator set, and on coordinating basic motions to perform specific tasks for which the equipment is designed. Since nearly every job presents a different problem, the operator may have to vary given procedures to fit the individual job.

### 2-11. Starting

a. *Preparation for Starting.*

- (1) Perform necessary daily preventive maintenance service (para. 3-4).
- (2) Set fuel tank selector valve handle to the left and fill fuel tank (para. 25) or connect external fuel tank to fuel tank selector valve and set valve handle to the right. (fig. 2-1).

**Note.**

**If external fuel tank is used, keep the tank on the same level as the generator (3) Insure no load is connected to generator prior to starting. Load may be applied after engine reaches operating temperature.**

b. *Starting.*

- (1) If engine is cold, loosen fuel tank cap. This will relieve a vacuum which may have formed in a cold fuel tank. Retighten cap prior to starting engine to prevent spillage of fuel.
- (2) Set ignition switch (fig. 2-1) to ON.
- (3) If engine is cold, pull choke button (fig. 2-1) outward. If engine is warm, little or no choking should be required.
- (4) Pull the starter handle upward with quick short pulls. Do not pull the starter cord out to the end or allow it to snap back by itself. Hold the cord so it will rewind properly on the pulley.

- (5) When the engine fires, push choke button half way in and continue cranking until engine starts. The engine should normally start within one to five cranking attempts.

**Note.**

**If the carburetor and fuel line do not contain any fuel, which may be the case if the engine ran completely out of fuel or the system was drained for maintenance purposes, it may take more than five cranking attempts in order to start. This is especially true when the fuel is to be drawn from the auxiliary tank.**

- (6) If the engine does not start after a reasonable number of attempts have been made as described above, pull the choke button back out and try again.
- (7) As the engine warms up, push choke button slowly inward. Always operate the warm engine with the choke all the way in.

### 2-12. Stopping

Set ignition swish (fig. 2-1) to OFF.

### 2-13. Operation under usual Conditions

- a. Start the engine as described in paragraph 2-11.
- b. Insert the power plug of the associated equipment into output connector (fig. 2-1) to apply the load.
- c. The generator governor will automatically control the engine speed by varying the throttle lever. No manual control is required.
- d. Stop the engine as described in paragraph 2-12.

### 2-14. Operation in Moderate Cold

- a. Keep fuel tank full at all times to prevent moisture condensation. Keep fuel tank cap securely closed except immediately before starting when it is loosened to break a possible vacuum.

b. Use winter grade gasoline in fuel mixture for easier starting.

c. Start engine as described in paragraph 2-11.

Note. More than 5 pulls may be required to secure adequate priming.

d. Use extra care to insure that the engine reaches operating temperature before applying the load.

#### **2-15. Operation in Extreme Heat**

a. Check the cooling fins on the cylinder frequently to be sure they are clean and not damaged.

b. If possible, provide shade to protect the unit from direct rays of the sun.

#### **2-16. Operation in Dusty or Sandy Areas**

a. Shield the unit from dust. Take advantage of natural barriers which offer protection from blowing sand and dust.

b. Strain the fuel-oil mixture before adding it to the fuel tank. Make sure the mixing container is clean.

c. Check air cleaner frequently. Clean if necessary. In extremely dusty conditions such as encountered on a sandy beach or desert, use two air cleaner elements, one on top of the other.

d. Clean the generator set frequently. Wipe with a cloth dampened with an approved cleaning solvent.

e. Operate the generator set at least a few inches above ground level to reduce intake of dirt and dust.

#### **2-17. Operation Under Rainy or Humid Conditions**

a. Where the generator set is not in operation, keep it in the carrying case.

b. Keep fuel tank full at all times to prevent moisture condensation.

#### **2-18. Operation in Salt Water Areas**

a. Avoid contact with salt water as corrosion can occur. If the generator set comes in contact with salt water, wash with fresh water. Dry thoroughly with compressed air, or moderate heat and ventilation.

b. Paint exposed metallic surfaces if paint has been removed. Coat exposed ferrous metal surfaces with standard issue rust proofing material if available, or cover parts with a light film of grease.

#### **2-19. Operation at High Altitudes**

a. Engine power output will decrease at a rate of 3 1/2 percent for each 1000-foot increase in elevation above sea level. The generator output will decrease accordingly as engine output decreases.

b. Maintain maximum performance by following all service instructions carefully. Be sure the air cleaner element is not clogged.

c. The carburetor may require readjustment for high altitude operation.

**CHAPTER 3**  
**OPERATOR AND ORGANIZATIONAL MAINTENANCE**  
**INSTRUCTIONS**

**Section I. SPECIAL TOOLS AND EQUIPMENT**

**3-1. Special Tools and Equipment**

The only special tool required by operator or organizational maintenance personnel for maintenance of the generator set is a muffler cleaning tool, which can be fabricated as shown in figure 3-1. The tool is used to

clean out clogged perforations of the muffler as described in paragraph 3-8 and as shown in figure 3-4.

**3-2. Basic Issue Tools and Equipment**

Repair parts issued with the generator set are listed in the basic issue items list, appendix B of this manual.

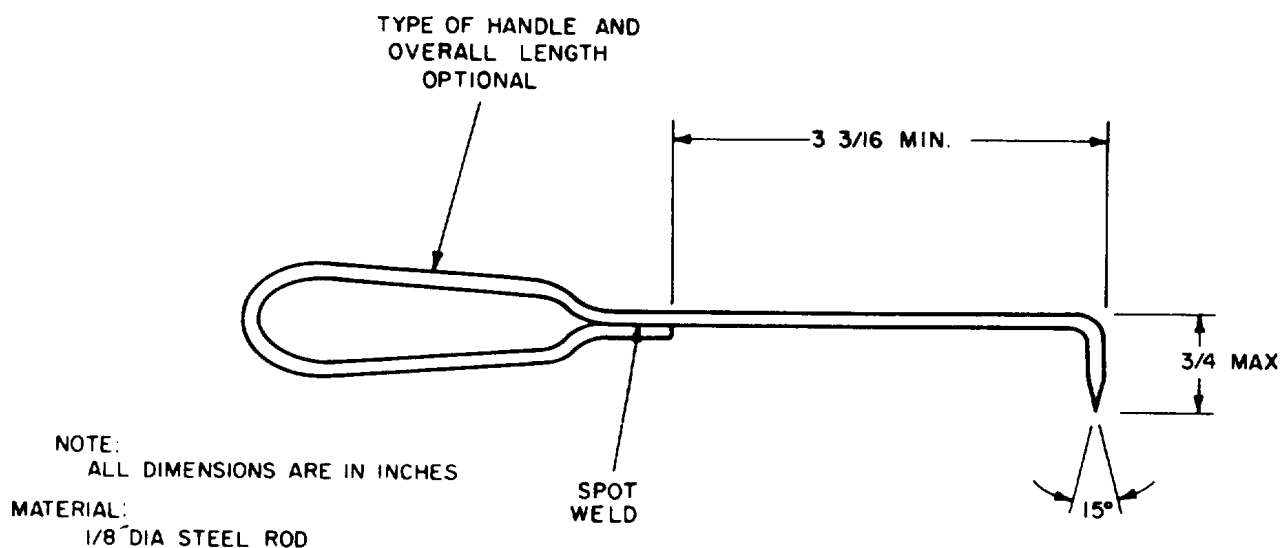

MEC 6115-405-15/3-1

**Figure 3-1. Fabrication of muffler cleaning tool**

**Section II. PREVENTIVE MAINTENANCE SERVICES**

**3-3. General**

To insure that the generator set is ready for operation at all times, it must be inspected systematically so that defects may be discovered and

corrected before they result in serious damage or failure. The necessary preventive maintenance services to be performed are listed and described in paragraphs 3-4 and 3-5. Item numbers indicate the sequence of minimum inspection requirements. Defects

discovered during operation of the unit shall be noted for future correction, to be made as soon as operation has ceased. Stop operation immediately if a deficiency is noticed which would damage the equipment if operation were continued. All deficiencies and shortcomings will be recorded together with the corrective action taken on DA Form 2404 (Equipment Inspection and Maintenance Worksheet) at the earliest possible opportunity.

#### **3-4. Daily Preventive Maintenance Services**

This paragraph contains an illustrated tabulated listing of preventive maintenance services which must

be performed by the operator or organizational maintenance personnel. The item numbers are listed consecutively and indicate the sequence of minimum requirements. Refer to figure 3-2 for the daily preventive maintenance services.

#### **3-5. Quarterly Preventive Maintenance**

There are no quarterly preventive maintenance services that can be performed by either the operator or organizational maintenance personnel.

## PREVENTIVE MAINTENANCE SERVICES DAILY

TM 5-6115-405-15

HOMELITE MODEL XL1115/1/400-IP

GENERATOR SET

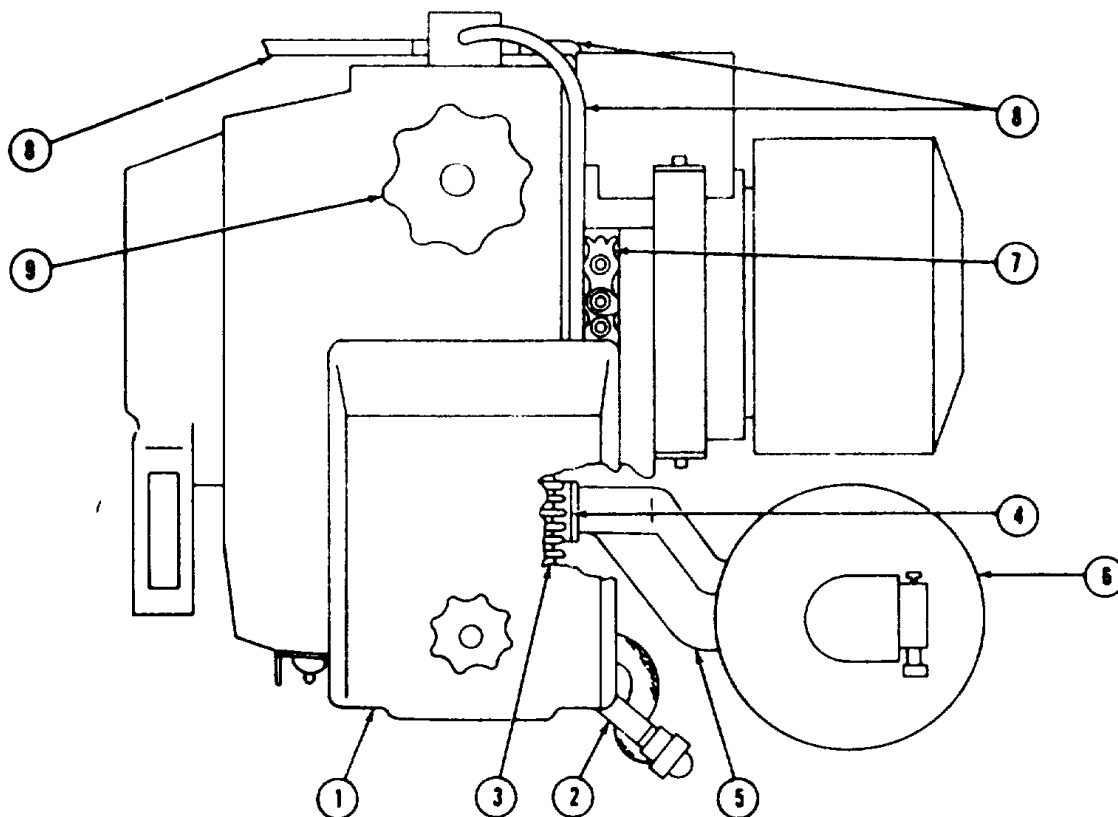

ITEM	PAR REF
1 <u>AIR CLEANER ELEMENT.</u> SERVICE AIR CLEANER ELEMENT.	3-7
1 <u>AIR CLEANER ELEMENT.</u> REPLACE AIR CLEANER ELEMENT. (100 HOURS)	3-7
2 <u>SPARK PLUG.</u> CLEAN AND REGAP. (30 HOURS)	3-11
2 <u>SPARK PLUG.</u> REPLACE. (50 HOURS)	3-11
3 <u>CYLINDER FINS.</u> CLEAN CYLINDER FINS. (WEEKLY)	3-9
4 <u>CYLINDER EXHAUST PORT.</u> CLEAN CYLINDER EXHAUST PORT. (10 HOURS)	3-9
5 <u>EXHAUST MANIFOLD.</u> CLEAN EXHAUST MANIFOLD. (50 HOURS)	3-9
6 <u>MUFFLER.</u> CLEAN MUFFLER. (50 HOURS)	3-8
7 <u>GOVERNOR.</u> CHECK GOVERNOR AND ADJUST SPEED. (50 HOURS)	3-12
8 <u>FUEL LINES.</u> INSPECT LINES FOR DAMAGE. REPLACE IF DAMAGED.	3-10
9 <u>FUEL TANK.</u> ADD FUEL AS REQUIRED.	2-5c

Figure 3-2. Daily preventive maintenance series.

## Section III. OPERATOR'S MAINTENANCE

## 3-6. General

Instructions in this section are published for the information and guidance of the operator to maintain the generator set.

## 3-7. Air Cleaner Element Service

a. Remove air cleaner element as shown in figure 3-3.

b. Wash the element in clean solvent (not fuel mix) and dry thoroughly before use. If cleaning with solvent is not possible, clean the element by tapping against a flat surface or by blowing out dust and dirt with a low pressure air hose.

c. Replace the element after 100 hours of operation or when it appears clogged and cleaning will not restore engine power.

## 3-8. Muffler Service

a. Loosen lock nut and unscrew muffler from exhaust manifold.

b. Using fabricated muffler cleaning tool (fig. 3-1), clean out all of the perforations of the muffler by inserting the tool into each end and picking out carbon deposits. (fig. 34.)

**Note.**

**It is necessary to clean from both ends because of the solid baffle in the center of the muffler.**

c. Before installing the muffler, clean the exhaust manifold and cylinder exhaust port. (para. 3-9.)

## 3-9. Cylinder Exhaust Port and Exhaust Manifold Service

a. Remove the two screws securing the exhaust manifold to the cylinder exhaust port. (fig. 3-4).

b. Turn the generator rotor by hand until the piston is at bottom dead center position. This will prevent damage to piston and rings and permit removal of loose carbon particles after cleaning exhaust by cranking the engine several times with manifold removed.

c. Using a wooden scraper, carefully remove the carbon deposits from the cylinder exhaust port. Be careful not to scratch the piston or damage the

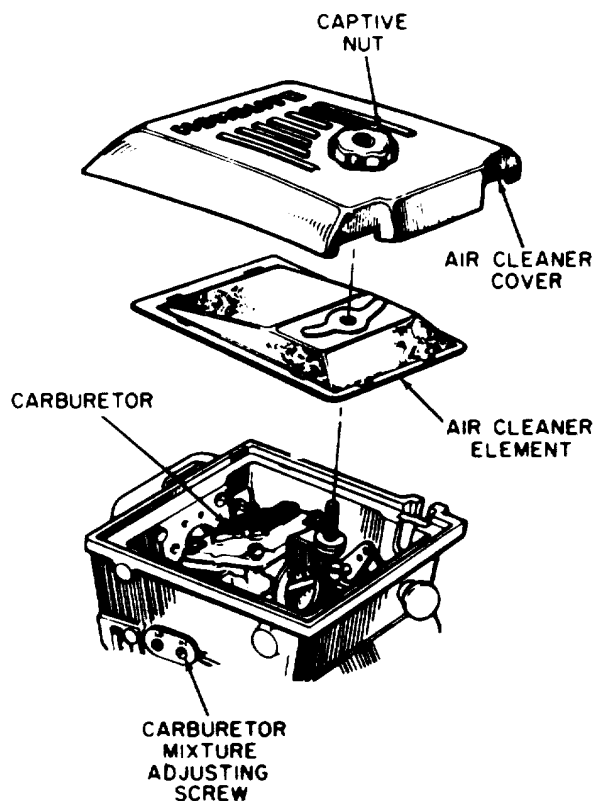

MEC 6115-405-15/3-3

Figure 3-3. Air cleaner element removal.

chamfered edges of the cylinder exhaust port. Clean the cylinder fins and blow out all loose particles from the exhaust manifold and cylinder exhaust port before reinstalling the exhaust manifold and muffler.

## 3-10. Fuel Line Replacement

If fuel line replacement is required, the method of installing the new lines over the fittings is to heat the ends of the new fuel lines in a port of boiling water until they are soft. While soft, the line can be stretched easily over the fitting as required. This softening is required only on new fuel lines, since once they are stretched, they will retain their shape.



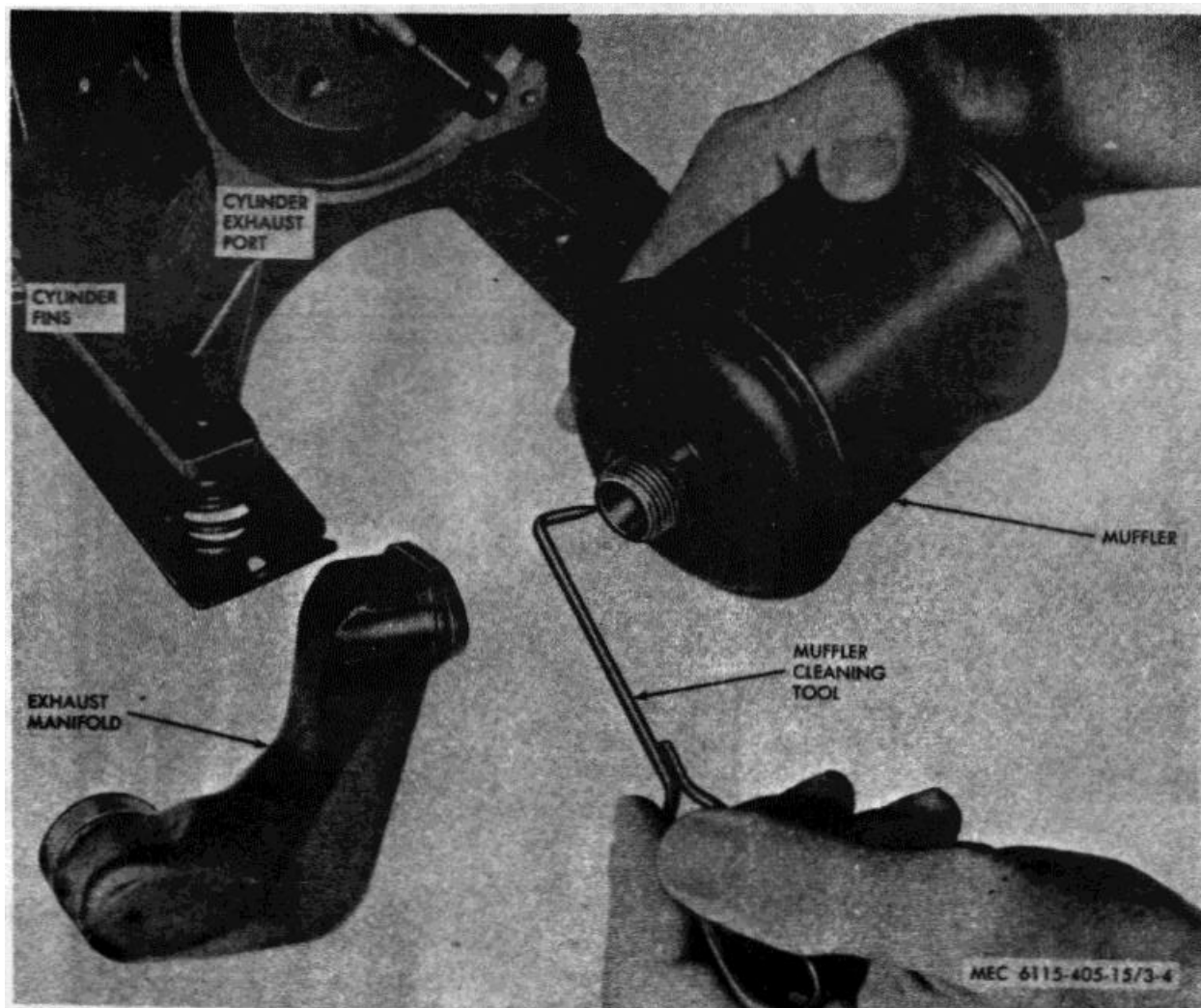

Figure 3-4. Muffler cleaning.

### 3-11. Spark Plug Service

a. Prior to removing the spark plug, use a 3/4-inch open end wrench to loosen the shielded ignition cable connecting nut. Unscrew the nut and separate the cable from the spark plug.

b. Using a 13/16-inch deep socket wrench, remove the spark plug.

c. Inspect the spark plug and clean or replace as necessary.

d. Clean the spark plug by wire-brushing and by digging out carbon around the insulator with a sharp instrument.

e. Using a 0.030-inch feeler gage, set the spark plug gap.

f. Install the spark plug and tighten to a torque of 250 to 300 lb in. using a 13/16-in. deep socket and torque wrench.

g. Insert the shielded ignition cable end into the spark plug and tighten the connector nut with a 3/4-in. open end wrench. Do not over tighten.

### 3-12. Governor Speed Adjustment

After each 50 hours of operation, check the speed of the generator set, using a tachometer or frequency meter. The proper speed is 400 rpm and the frequency is 400 cps. If adjustment is required, proceed as follows:

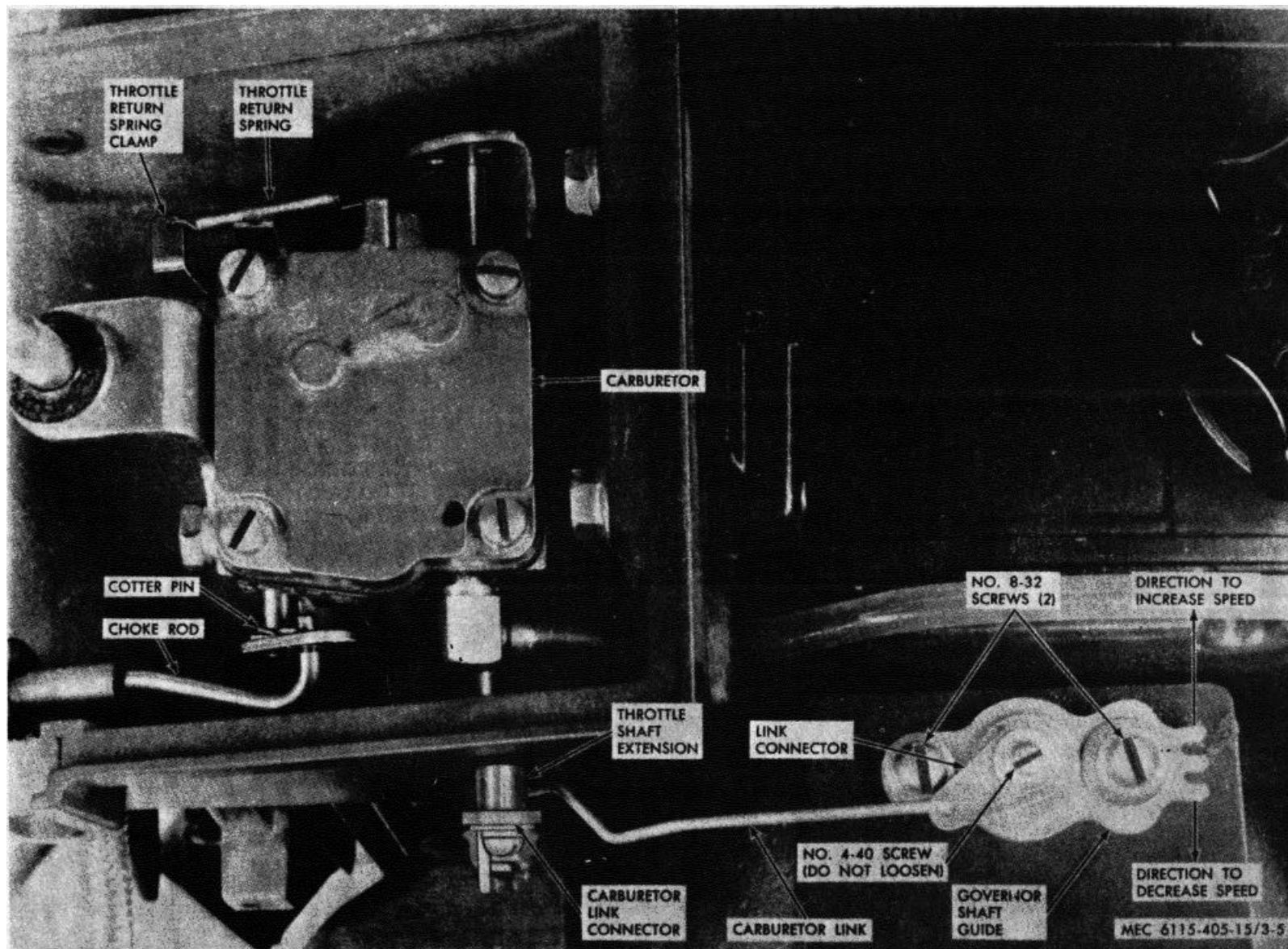

Figure 3-5. Governor speed adjustment.

**Caution:**

**Under no circumstances should the speed be changed by pushing against the carburetor linkage. Moving this linkage even for an instant will cause immediate damage to the governor.**

- a. Allow the generator set to operate until it is warm and has stable output.
- b. Keep a slight pressure on governor shaft guide (fig. 3-5) to prevent unwanted movement, and loosen the two outer No. 8-32 screws.

**Caution:**

**Do not loosen the center No. 440 screw or the governor shaft will fall into the engine housing.**

c. Move the toothed end of governor shaft guide in small increments until speed is adjusted as required. Note the direction of movement for increase and decrease as indicated on figure 3-5.

d. When speed is correct, maintain slight pressure on the governor shaft guide and tighten the two outer No. 832 screws.

**Note.**

**Do not loosen or attempt to adjust the throttle return spring clamp screws inside the carburetor chamber assembly.**

**Section IV. TROUBLESHOOTING**

**3-13. General**

This section provides information useful in diagnosing and correcting unsatisfactory operation or failure of the generator set and its components. Each trouble symptom stated is followed by a list of probable causes. The possible remedy recommended is described opposite the probable cause. Any trouble beyond the scope of organizational maintenance shall be reported to direct support maintenance.

**3-14. Engine Fails to Start or Starts with Difficulty**

<i>Probable cause</i>	<i>Possible remedy</i>
Ignition switch not set correctly.	Set ignition switch to ON.
No fuel in tank .....	Fill fuel tank (para 2-5c).
Fuel tank selector valve set to incorrect position.	Set valve as required (para 2-11a).
Spark plug fouled with fuel or excessive carbon.	Clean or replace spark plug (para 3-11).
Spark plug gap incorrect .....	Regap spark plug (para 3-11).
Muffler clogged .....	Clean muffler (para 3-8).
Exhaust manifold or cylinder exhaust port clogged;.	Clean exhaust manifold and cylinder exhaust port (para 3-9).
Air cleaner element clogged.	Clean or replace air cleaner element (para 3-7).
Water or dirt in fuel tank.	Drain, clean, and refill fuel tank with correct fuel mixture (para 2-5c).
Engine needs choking .....	Pull choke button out and restart.
Fuel tank cap valve clogged.	Remove cap and restart. If engine runs better, replace fuel tank cap.

<i>Probable cause</i>	<i>Possible remedy</i>
Breaker points defective or improperly gapped.	Regap or replace breaker points (report this condition to direct support maintenance).
Capacitor defective .....	Replace capacitor (report this condition to direct support maintenance).
Carburetor dirty or defective.	Clean or replace defective parts (report this condition to direct support maintenance).
Starter binding or defective.	Disassemble and correct trouble (report this condition to direct support maintenance).

**Note.**

**A quick check of generator set condition for troubleshooting purposes is to disconnect shielded ignition cable from spark plug (para 3-11a), and hold end of the cable approximately 1/4 inch from rear end of spark plug while pulling starter handle (this may require two men). If sparks do not jump, the trouble is in the electrical system. (Report this condition to direct support maintenance.) If sparks jump, replace spark plug. If this does not correct the problem, the trouble is in the fuel system. Check fuel lines, fuel tank, carburetor, etc.**

**3-15. Engine Overheats or Locks Power**

<i>Probable cause</i>	<i>Possible remedy</i>
Incorrect fuel mixture .....	Drain, clean, and refill fuel tank with correct fuel mixture (para 2-5c).

<i>Probable cause</i>	<i>Possible remedy</i>
Choke closed .....	Push in choke button fully to open choke.
Carburetor improperly adjusted.	Adjust carburetor (para 3-23).
Muffler, exhaust manifold, or cylinder exhaust port clogged.	Clean muffler (par. 3-8), exhaust manifold, and cylinder exhaust port (para 3-9).
Cylinder fins clogged .....	Clean cylinder fins.
Inadequate ventilation.....	Provide adequate cooling air flow (para 2-5).
Engine speed incorrect	Adjust governor (para 3-12).
Engine or generator parts binding.	Perform overhaul (report this condition to direct support maintenance).
Air leak in fuel line from fuel tank to carburetor.	Inspect and replace fuel line if required (para 3-10).
Ruptured fuel pump diaphragm.	Disassemble carburetor and correct trouble (report this condition to direct support maintenance).
Spark plug fouled .....	Clean and regap or replace spark plug (para 3-11).

### 3-16. Engine Misfires

<i>Probable cause</i>	<i>Possible remedy</i>
Choke closed .....	Push in choke button fully to open choke.
Carburetor improperly adjusted.	Adjust carburetor (para 3-23).
Spark plug fouled .....	Clean and regap or replace spark plug (para 3-11).
Shielded ignition cable, ignition coil, or breaker points defective.	Replace defective parts (report this condition to direct support maintenance).

### 3-17. Excessive Smoke from Muffler

<i>Probable cause</i>	<i>Possible remedy</i>
Excessive oil in fuel mixture.	Drain fuel tank and fill with correct fuel mixture (para 2-5c).
Carburetor set too rich.....	Adjust carburetor (para 3-28).
Air cleaner clogged .....	Inspect air cleaner and clean as necessary.

## Section V. RADIO INTERFERENCE SUPPRESSION

### 3-18. Definitions

*a. Interference.* The term "interference" as used herein applies to electrical disturbances in the radio frequency range which are generated by the generator set and which may interfere with the proper operation of radio receivers or other electronic equipment, or enable the enemy to locate the equipment.

*b. Interference Suppression.* The term "interference suppression" as used herein applies to the methods used to eliminate or effectively reduce radio interference generated by the generator set.

### 3-19. General Methods Used to Attain Proper Suppression

Essentially, suppression is attained by providing a low resistance path to ground for stray currents.

Methods used include shielding the ignition and high-frequency wires, grounding the frame with bonding straps, and using capacitors and resistors.

### 3-20. Interference Suppression Components

The suppression components used on the generator set are the shielded ignition cable (fig. 1-1) and the integral suppressor-type spark plug.

### 3-21. Replacement of Suppression Components

Replacement of the shielded ignition cable is beyond the scope of organizational maintenance personnel. Refer to direct support maintenance instructions given in chapter 6. For replacement of the spark plug, refer to paragraph 3-11.

## Section VI. CARBURETOR

### 3-22. General

The carburetor is located under the air cleaner element cover directly below the air cleaner element. (fig. 33.)

### 3-23. Carburetor Adjustment

**Note.**

**Before attempting to remedy a trouble by adjusting the carburetor, be sure that the air cleaner element is clean, and the fuel is fresh, clean, and correctly mixed.**

a. Turn carburetor mixture adjusting screw (fig. 3-3) gently clockwise until it just closes against its seat. Open it counterclockwise approximately 3/4 turn. This preliminary setting will facilitate starting the engine.

b. Start the engine, allow it to warm up, and apply the load.

c. Slowly close (clockwise) the carburetor mixture adjusting screw 1/8 turn at a time until the engine speed begins to decrease. Note this setting.

d. Slowly open (counterclockwise) the carburetor mixture adjusting screw 1/8 turn at a time until the engine speed again begins to decrease. Note this setting.

e. Make the final adjustment by setting the carburetor mixture adjusting screw midway between the two settings noted in steps c and d.

CHAPTER 4

DIRECT AND GENERAL SUPPORT AND DEPOT  
MAINTENANCE INSTRUCTIONS

Section I. GENERAL

4-1. Scope

These instructions are published for the use of direct and general support and depot maintenance personnel maintaining the Homelite Model XLA115/1/400-1P generator set. They provide information on the maintenance of the equipment, which is beyond the scope of tools, equipment, personnel, or supplies normally available to using organizations.

4-2. Record and Report Forms

For record and report forms applicable to direct and general support and depot maintenance, refer to TM 38-750.

**Note.**

**Applicable forms, excluding Standard Form 46 (United States Government Motor Vehicle Operator's identification card) which is carried by the operator, shall be kept in the publications case mounted in the carrying case cover.**

Section II. DESCRIPTION AND TABULATED DATA

4-3. Description

For a complete description of the generator set see paragraph 1-3.

4-4. Tabulated Data

a. *General.* This paragraph contains all the overhaul data pertinent to direct and general support and depot maintenance personnel. Figure 1-4 is a practical wiring diagram of the generator set.

b. *Generator classification and rating*

Type.....	Permanent magnet
Rating .....	125 watts
Output voltage .....	115 volts ac
Phase.....	Single
Power factor .....	1.0
Frequency .....	400 cps
Cooling .....	Air
c. <i>Generator stator -repair standards.</i>	
Number of poles .....	12
Number of coils .....	45
Turns per coil .....	7

Wire size .....	No 21 AWG
Type of wire .....	Heavy Formvar or equal
Insulating materials .....	Shell epoxy 828 or equal
Lead wire length .....	8 in.
End treatment .....	Solder-dip
d. <i>Torque data.</i>	
Spark plug .....	250-330 in. lb
Connecting rod cap .....	55-60 in. lb screws.
Magneto rotor nut .....	150-200 in. lb
No. 4 spinlock screws .....	5 in lb min
No. 6 spinlock screws .....	20 in. lb min
No. 8 spinlock screws .....	36 in. lb min
No 10 spinlock screws .....	50 in. lb min
No. 12 spinlock screws .....	80 in. lb min
1/4 in. spinlock screws .....	120 in. lb min
No. 4-40 ordinary .....	4 3/4 in. lb min screws.
No 6-32 ordinary .....	8 3/4 in. lb min screws.
No. 8-32 ordinary .....	18 in. lb min screws
No 8-36 ordinary .....	20 in. lb min screws.
No. 10-24 ordinary .....	23 in. lb min screws.

No. 10-32 ordinary screws. 32 in. lb min  
 No. 12-24 ordinary screws 50 in. lb min  
 1/4 in ordinary screws..... 100 in. lb min

e. *Repair and replacement standards.* Table 4-1 lists manufacturer's sizes, tolerance, desired clearances, and maximum allowable wear and clearances.

**Table 4-1. Repair and Replacement Standard**

Component	Manufacturer's dimensions and tolerances in inches		Desired clearance		Maximum allowable wear and clearance
	minimum	maximum	minimum	maximum	
GENERATOR SHAFT:					
Needle bearing journal.....	0.6245	0.6250	0.0006	0.0010	0.0006
Rotor journal.....	0.4995	0.5000	0.0005	0.0020	0.0006
Governor cup journal.....	0.7495	0.7500	0.0030	0.0045	0.0005
CRANKSHAFT:					
Needle bearing journals.....	0.6245	0.6250	0.0006	0.0010	0.0006
Connecting rod roller journal ...	0.5565	0.5570	--	--	0.0005
CONNECTING ROD:					
Needle bearing journal .....	0.5615	0.56'25	--	--	0.0010

CHAPTER 5

GENERAL MAINTENANCE INSTRUCTIONS

Section I. SPECIAL TOOLS AND EQUIPMENT

**5-1. Special Tools and Equipment**

No special tools and equipment are required.

general support and depot maintenance personnel performing major overhaul work on the generator set. Tools listed in table 5-1 are not available for issue, but must be fabricated by qualified direct and general support and depot maintenance personnel.

**5-2. Specially Designed Tools and Equipment**

The specially designed tools listed in table 5-1 and illustrated in figures 5-1 through 5-7 are for direct and

Table 5-1. Specially Designed Tools

Item	Reference		Use
	Figure	Paragraph	
Rotor locking tool (23960).....	5-1	5-12, 5-13, 6-2, 6-4, 6-6	Hold magneto rotor when removing or installing rotor shaft nut or generator rotor.
Offset wrench (24002) .....	5-2	6-14, 6-16	Remove and install cylinder nuts.
Needle bearing assembly tool..... (23756)	5-3	6-14, 6-16	Remove and install needle bearing in connecting rod (piston end)'. Remove needle bearing and seal from crankcase, remove and install needle bearing in stator mounting plate, and install needle bearing in crankcase.
Bearing and seal tool (23757) .....	5-4	6-6, 6-8, 6-14, 6-16	Install seal in crankcase.
Seal assembling plug (23758).....	5-5	6-16	Protect seal when installing crankshaft into crankcase.
Seal assembling sleeve (23759) .....	5-6	6-16	Remove piston pin from piston.
Piston pin removal tool (23949) .....	5-7	6-14	



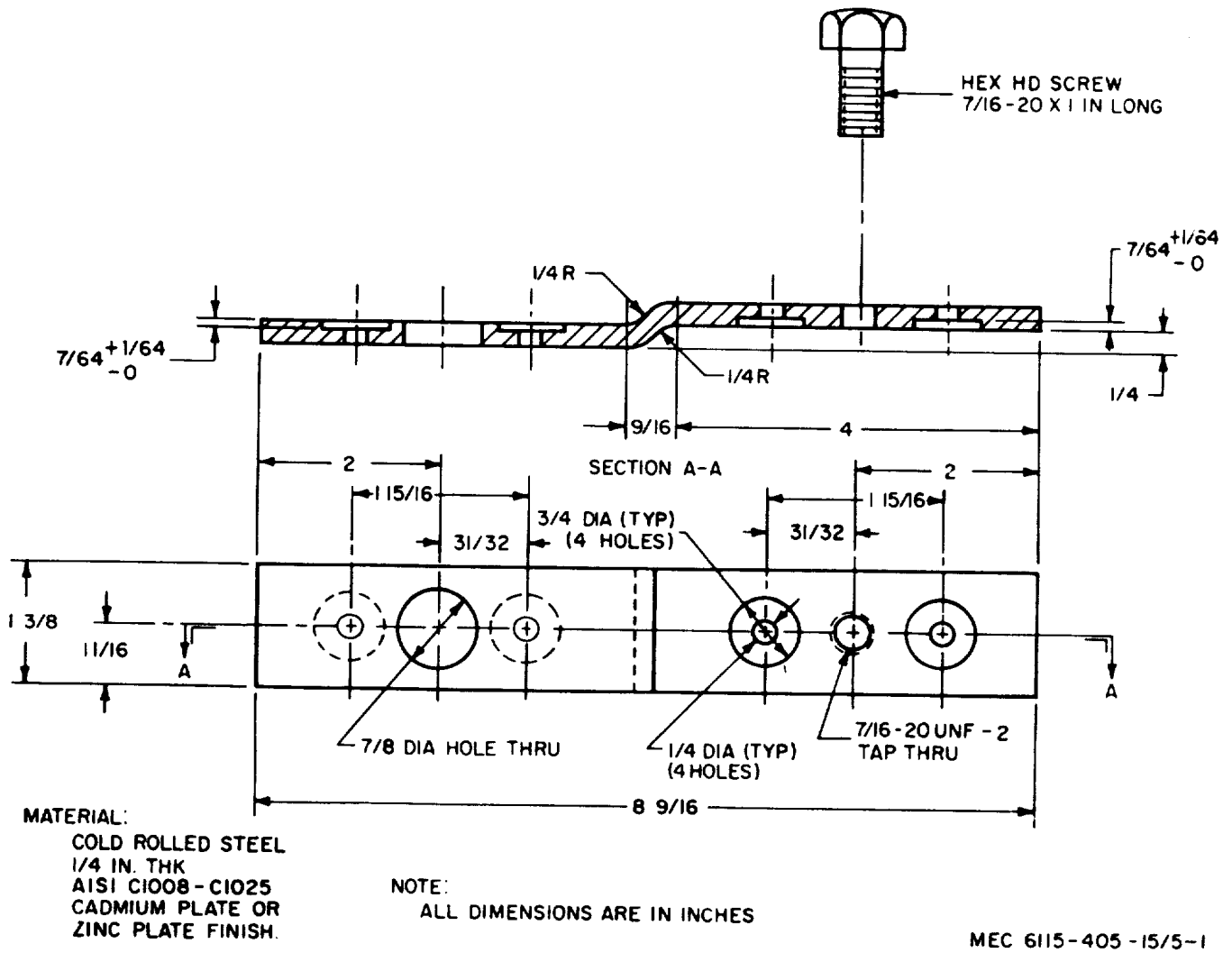
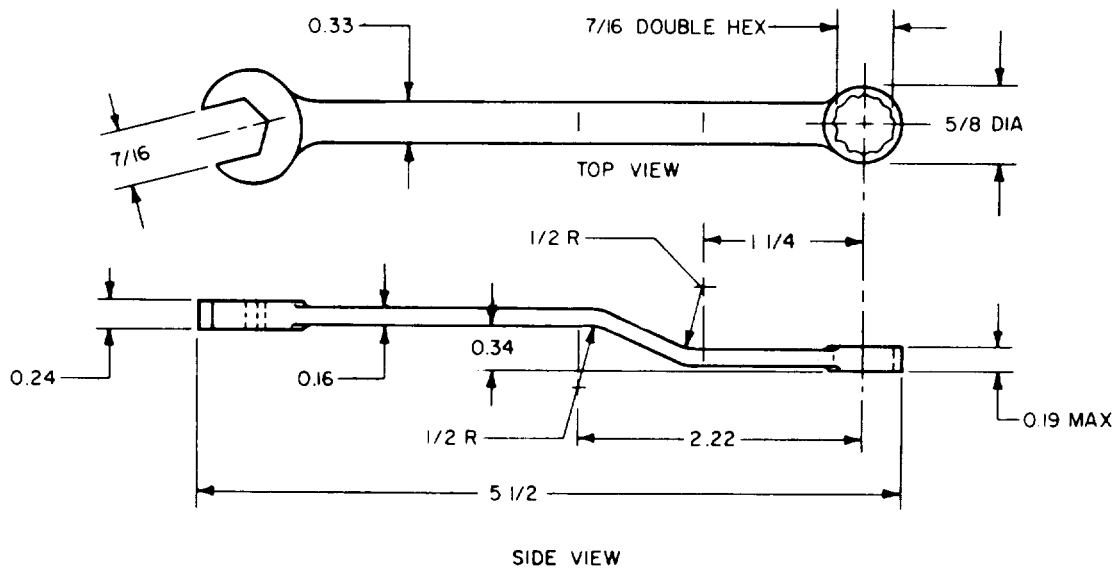

Figure 5-1. Fabrication of rotor locking tool.



MATERIAL:  
 4140 STEEL  
 ROCKWELL "C"-45-47  
 BLACK OXIDE FINISH

NOTE:  
 ALL DIMENSIONS ARE IN INCHES.

MEC 6115-405-15/5-2

Figure 5-2. Fabrication of offset wrench.

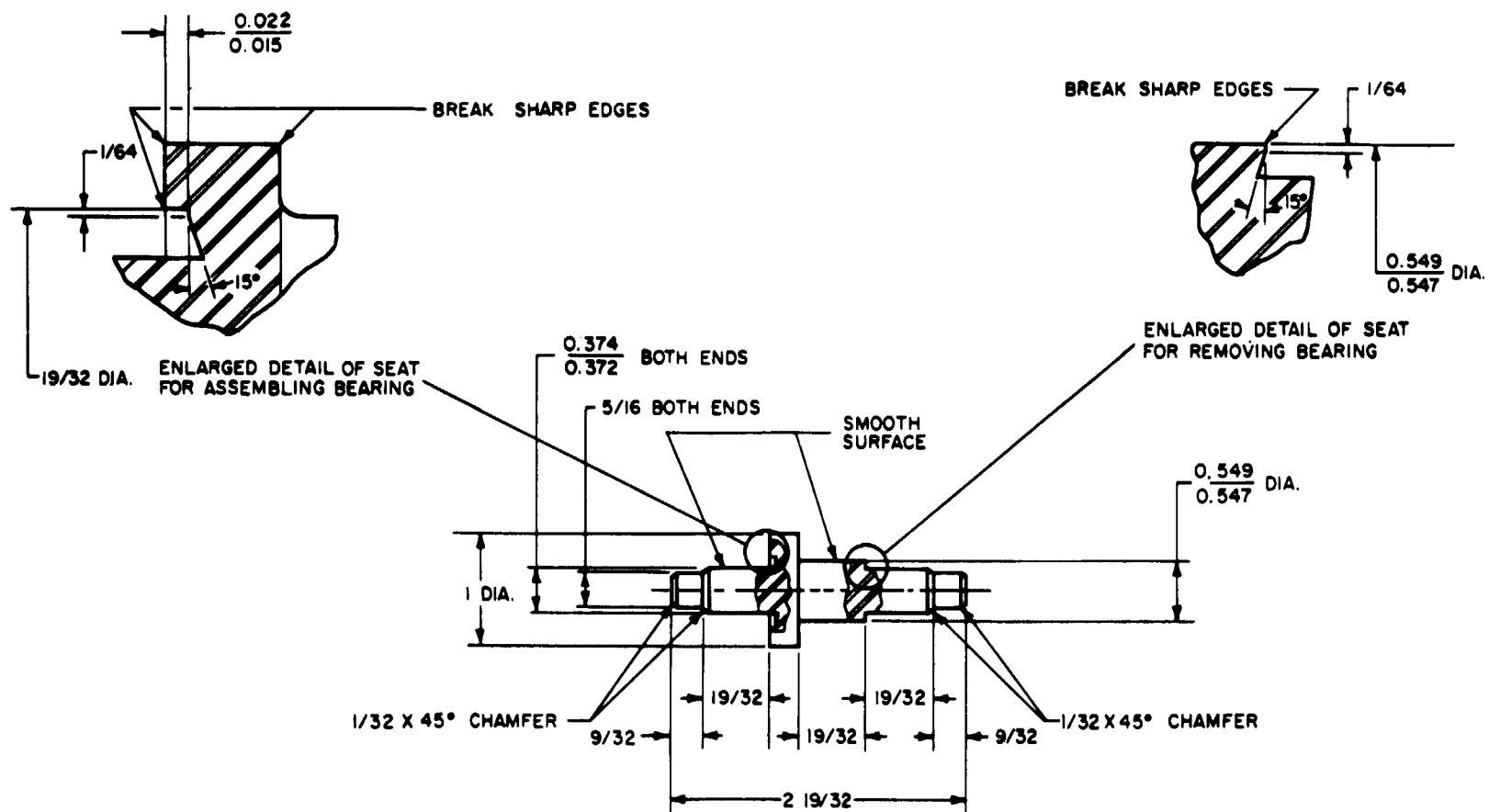

**MATERIAL:**

COLD ROLLED STEEL AISI B1112-B1113 ROCKWELL "15N"-85 MIN.  
CADMIUM PLATE OR ZINC PLATE FINISH, RELIEVE AT 375° F  
FOR 4 HOURS AFTER PLATING.

**NOTE:**

ALL DIMENSIONS ARE IN INCHES.

MEC 6115-405-15/5 - 3

Figure 5-3. Fabrication of needle bearing assembling tool.

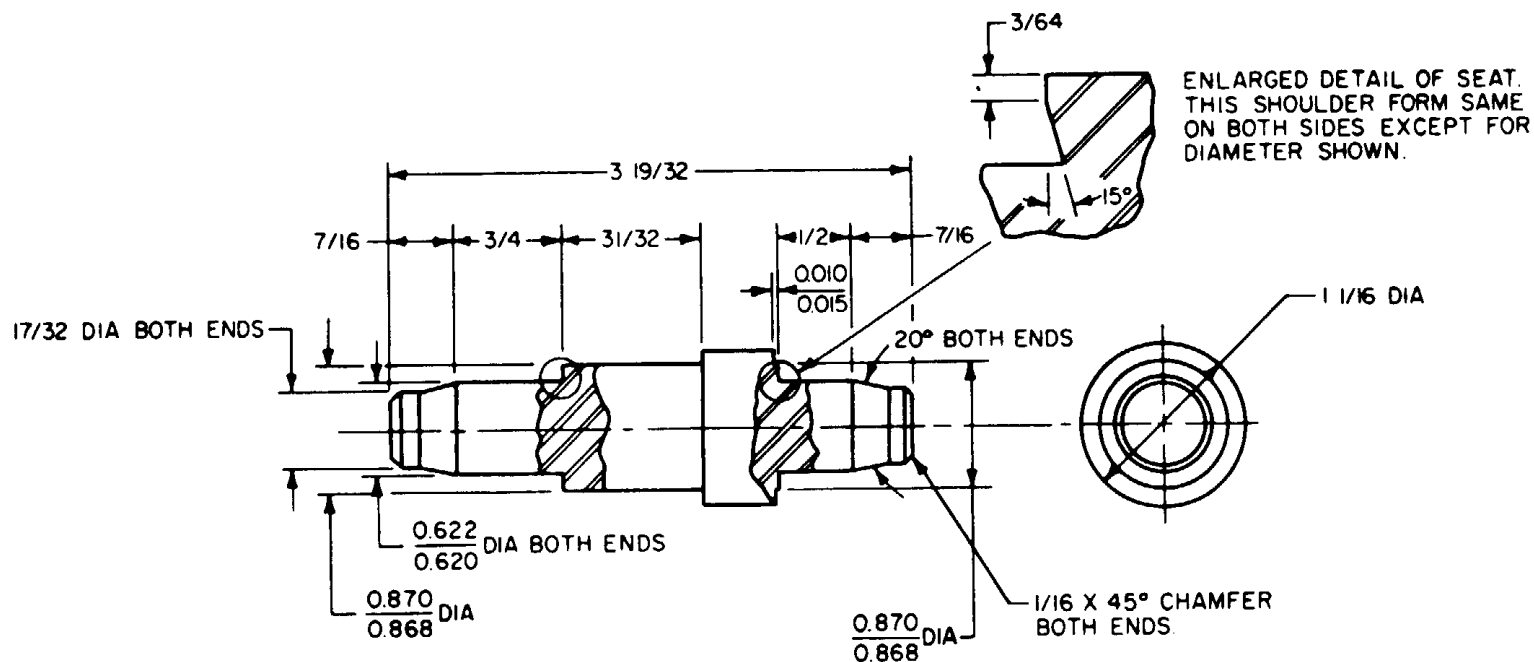

**MATERIAL:**  
 COLD ROLLED STEEL AISI B1112-B1113  
 ROCKWELL "15N" - 85 MIN.  
 CADMIUM PLATE OR ZINC PLATE FINISH  
 RELIEVE AT 375°F FOR 4 HOURS AFTER PLATING.

**NOTE:**  
 ALL DIMENSIONS ARE IN INCHES.

Figure 5-4. Fabrication of seal assembling sleeve.

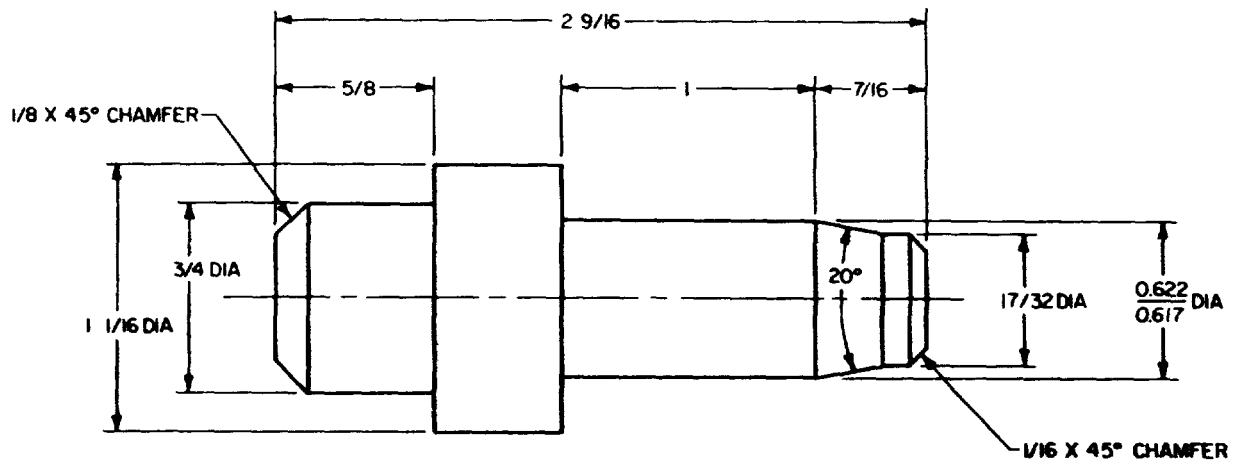

**MATERIAL:**

COLD ROLLED STEEL AISI B112-C1117 OR C1018  
 ROCKWELL "15N" - 85 MIN.  
 CADMIUM PLATE OR ZINC PLATE FINISH  
 RELIEVE AT 300° F FOR 4 HOURS MIN. AFTER PLATING.

**NOTE:**

ALL DIMENSIONS ARE IN INCHES.

MEC 6115-405-15/5-5

Figure 5-5. Fabrication of seal assembling plug.

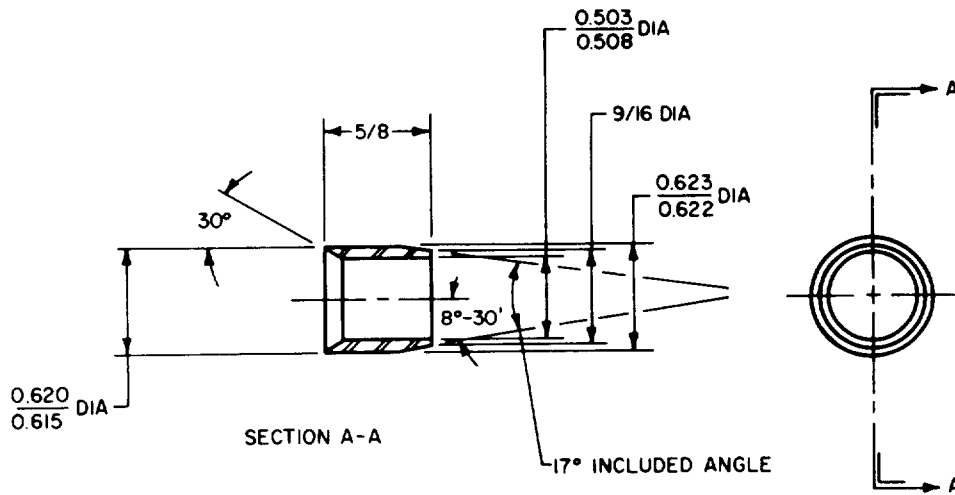

**MATERIAL:**

COLD ROLLED STEEL AISI B1112-B1113  
 CADMIUM PLATE OR ZINC PLATE FINISH

**NOTE:**

ALL DIMENSIONS ARE IN INCHES.

MEC 6115-405-15/5-6

**Figure 5-6. Fabrication of seal assembling sleeve.**

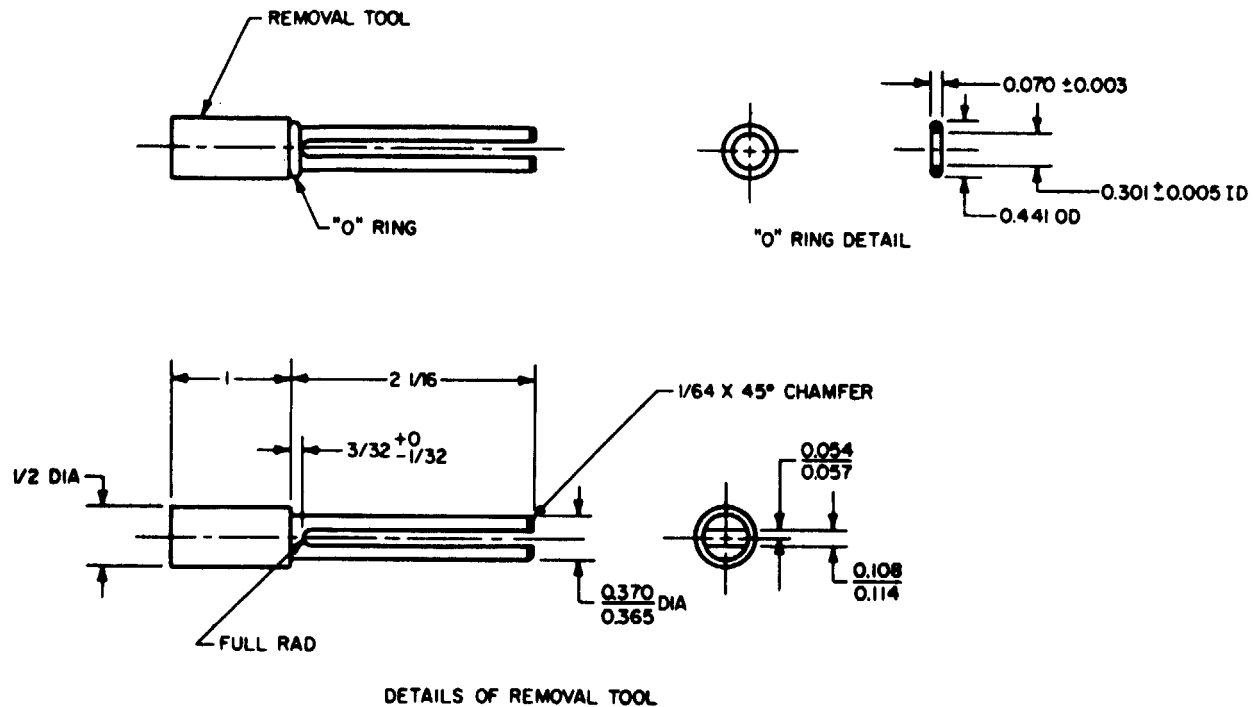

**MATERIAL:**  
 TOOL STEEL  
 ROCKWELL "C" 55-60  
 "O" RING-BLACK SYNTHETIC RUBBER  
 ASTM SB720 BE<sub>1</sub>E<sub>3</sub>F<sub>1</sub>

**NOTE:**  
 ALL DIMENSIONS ARE IN INCHES.

MEC 6115-405-15/5-7

Figure 5-7. Fabrication of piston pin removal tool.

**Section II. TROUBLESHOOTING**

**5-3. General**

This section provides information useful in diagnosing and correcting unsatisfactory operation or failure of the generator set or any of its components. Each trouble symptom stated is followed by a list of probable causes. The possible remedy recommended is described opposite the probable cause.

**5-4. Engine Fails to Start or Starts With Difficulty**

Probable cause	Possible remedy
Breaker points defective or improperly gapped.	Regap or replace breaker points (para 6-4).
Capacitor defective .....	Replace capacitor (para 6-4).
Carburetor dirty or defective.	Clean or replace defective carburetor parts (para 6-19 and 6-20).
Starter binding or defective.	Check and correct trouble (para 6-4).
Spark plug overheated indication (electrode burned, insulator tip light gray or chalk white).	Check for carbon-clogged muffler (para -8), cylinder exhaust port and exhaust manifold (para 3-9), lean carburetor setting (para 2-23), air leak in fuel line from fuel tank to carburetor (para 3-10), or ruptured fuel pump diaphragm in carburetor (para 6-19).
Spark plug wet fouled indication (insulator tip black, damp oily film over firing end, carbon layer over entire nose).	Check for incorrect carburetor adjustment (para 3-23), air cleaner element clogged (para 3-7), wrong fuel mix (para 2-c), or faulty ignition parts (para 6-3).

Probable cause	Possible remedy
Spark plug oxide fouled indication (electrode covered with ashlike deposits).	Check for excessive combustion chamber deposits (para 6-15), clogged muffler (para 3-4), clogged cylinder exhaust port or exhaust manifold (para 3-9), use of non-recommended oil, or too much oil in fuel mix (para 26-).

**5-5. Engine Lacks Power**

Probable cause	Possible remedy
Piston rings worn	Replace piston rings (para 6-16).
Cylinder worn or scored	Replace cylinder (para 6-16).
Damaged bearings	Replace bearings (para 6-8 and 6-16).
Carburetor dirty	Clean or replace defective carburetor parts (para 6-19 and 6-20).
Parts binding	Check and replace damaged parts (para 6-16).
Damaged or leaking crankcase.	Check crankcase for cracks or broken gaskets (para 6-15).

**5-6. Engine Speed Erratic or No Generator Output**

Probable cause	Possible remedy
Governor parts damaged	Replace damaged parts (para 6-8).
Generator stator windings damaged.	Replace generator stator (para 6-8).
Governor to carburetor linkage parts damaged or incorrectly assembled or adjusted	Adjust linkage (para 3-12) or replace damaged parts (para 6-12).
Intermediate ignition coil failure.	Replace coil (para 6-3).

**Section III. RADIO INTERFERENCE SUPPRESSION**

**5-7. General**

Refer to TM 11-483 for definitions, purposes, source and methods used to obtain proper radio suppression.

**5-8. Interference Suppression Components**

The suppression components used on the generator set

are the shielded ignition cable (fig. 1-1) and the integral suppressor-type spark plug.

**5-9. Replacement of Suppression Components**

*a. Removal.*

- (1) Disconnect the shielded ignition cable from the spark plug, using a 3/4-



inch open end wrench. Remove spark plug (para 3-11).

- (2) Remove the fan housing assembly (para 5-11) to gain access to the ignition coil.
- (3) Loosen ground screw to free shield ground terminal of shielded ignition cable. Turn the shielded ignition cable counterclockwise until it is free from the ignition coil.

*b. Testing.* Check for visible damage (cracked or burned ceramic sleeve, damaged spring clip, abraded insulation). Using an ohmmeter, check that the shielded ignition cable is not open-circuited.

*c. Installation.*

- (1) Twist the shielded ignition cable clockwise into the cable well of the ignition coil until it is securely fastened.
- (2) Insert shield ground terminal of ignition cable under ground screw, and tighten screw.
- (3) Install fan housing assembly (para 5-11).
- (4) Install spark plug (para 3-11).
- (5) Insert the shield ignition cable into the open end of the spark plug and fasten with the cable nut. Tighten with a 3/4-inch open end wrench.

## Section IV. REMOVAL AND INSTALLATION OF MAJOR COMPONENTS

### 5-10. General

The major components which make up the generator set, and which can be easily removed as major assemblies are the starter fan housing, generator, ignition parts, and carburetor.

#### Note

**The crankshaft, connecting rod, and piston removal and installation are covered in Chapter 6.**

### 5-11. Starter Fan Housing

*a. Removal.*

- (1) Refer to figure 5-8 and remove the starter fan housing. Use a thin-walled 5/16-inch socket wrench or a large screwdriver to remove the four housing screws.
- (2) Lift the starter fan housing out far enough to disconnect the ignition switch lead at the ignition coil. Pull the lead straight out and the terminal will slide out easily.

*b. Installation.*

- (1) Position the starter fan housing close enough to the engine so that the ignition switch lead may be connected to the ignition coil. Slide the terminal straight onto the coil tab.
- (2) Hold the starter fan housing in place with one hand, and pull the starter handle out a short distance with the other hand until the starter fingers engage properly, and the

fan housing seats against the engine. Install and tighten the four screws and internal tooth lock washers. Note that the one shorter (5/8 in. long) screw is to be installed in the upper centrally located screw hole. (fig. 5-8.) The three remaining screws are 1 11/16 in. long.

#### Caution

**Fan housing must seat all around to avoid breakage of housing or starter fingers when screws are tightened.**

### 5-12. Generator

*a. Removal.*

- (1) Remove starter fan housing as described in paragraph 5-11.
- (2) Remove air screen by taking off two self-locking nuts.
- (3) Connect the fabricated rotor locking tool to the magneto rotor with the two self-locking nuts. (fig. 5-9.) (4) With the rotor locking tool preventing the shaft from turning, insert a 3/16-inch Allen wrench into the socket head screw in the generator rotor. Remove the screw, lock washer, and flat washer, and pull the generator rotor straight off the shaft. (fig. 5-10.) Lift out the key and set it aside to avoid losing it.

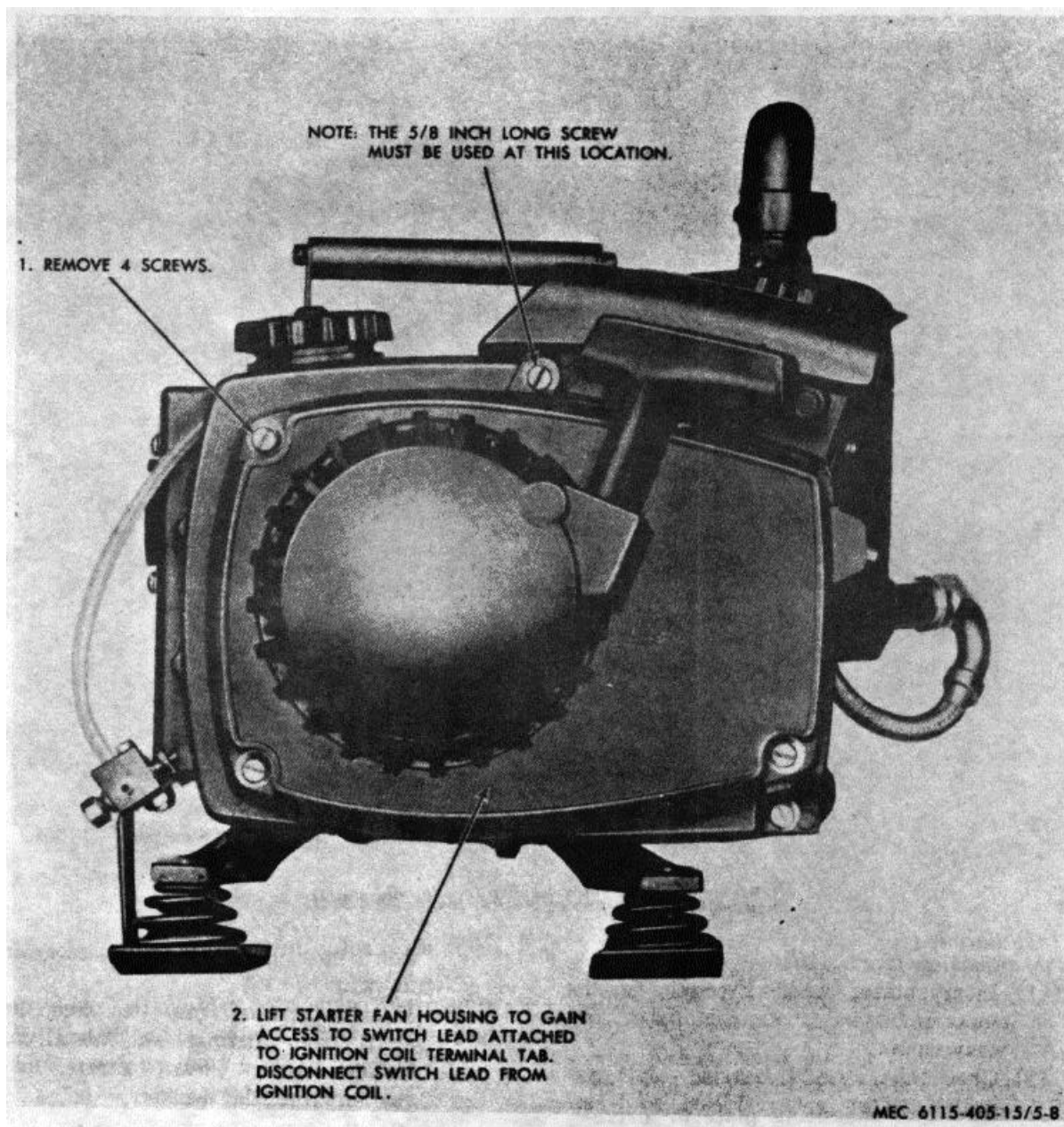

Figure 5-8. Removal of starter fan housing.

- (5) Remove two screws on the right-hand side holding the stator mounting plate, and slide out the junction box.
- (6) Remove two output connector screws. Disconnect stator leads from output connector.
- (7) Loosen cable clamp screw to free stator leads. Pull the leads through the grommets in the drivecase and the stator mounting plate.
- (8) Remove two remaining screws (left-hand side) holding stator mounting plate, and remove plate with generator stator attached.
- (9) Remove generator stator and needle bearing from stator mounting plate if required.

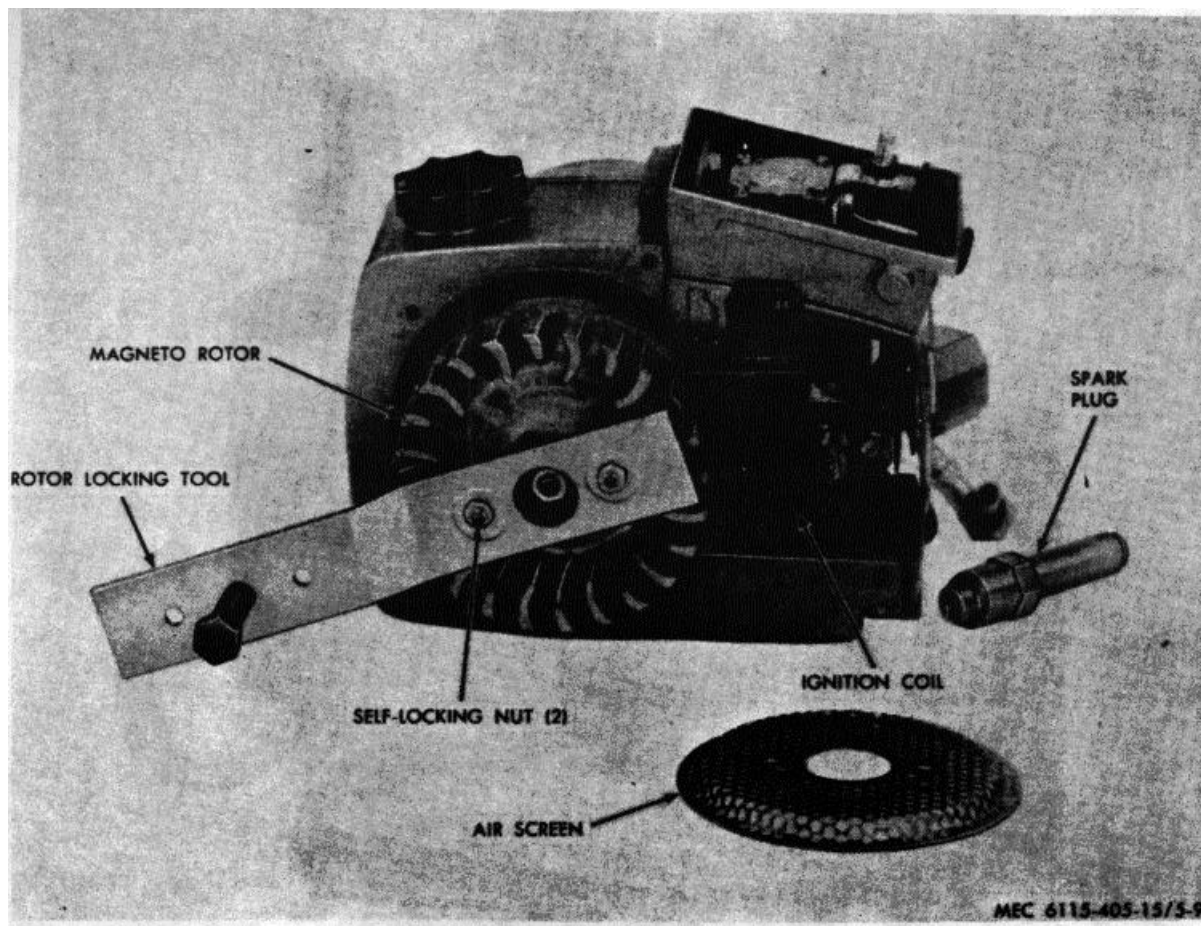

Figure 5-9. Using rotor locking tool to hold shaft.

b. *Installation* (fig. 5-10).

- (1) Insert stator leads through grommets in stator mounting plate and drivecase.
- (2) Check that needle bearing and generator stator are installed, and secure stator mounting plate to drivecase with left-hand side screws only.
- (3) Secure stator leads under cable clamp on drivecase and connect leads to output connector.
- (4) Secure output connector to junction box.
- (5) Position junction box over stator mounting plate and secure two remaining screws.
- (6) Aline keyway in generator rotor with keyway in shaft and mount generator rotor in position. Insert key in keyway.

- (7) Hold generator rotor to keep the shaft from turning, and install and tighten socket head screw, lockwasher, and flat washer.

**Caution**

**Do not use rotor locking tool to tighten screw.**

**5-13. Ignition Ports**

a. *Removal.*

- (1) Remove starter fan housing as described in paragraph 5-11.
- (2) Remove air screen by taking off two self-locking nuts.
- (3) Connect the fabricated rotor locking tool to the magneto rotor in the manner shown in figure 5-11.

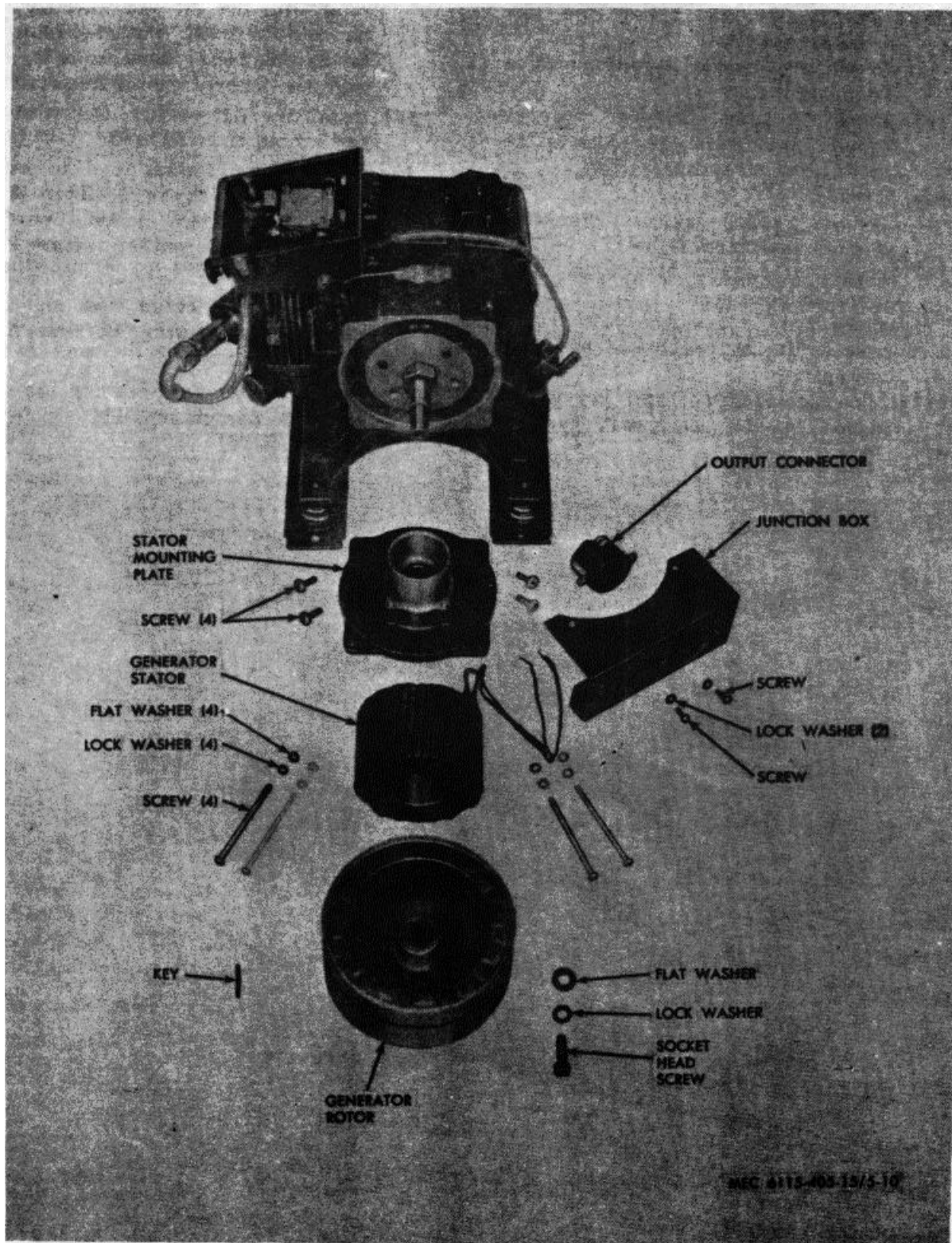

Figure 5-10. Generator removal.

- (4) Turn in the screw until the magneto rotor is free, and remove the tool and magneto rotor.
- (5) Disconnect shielded ignition cable from spark plug.
- (6) Remove three spinlock screws around stator plate, and remove the entire ignition system as unit.

*b. Installation.*

- (1) Position gasket against crankcase and felt seal on crankshaft.
- (2) Secure stator plate to cylinder with three spinlock screws. Before tightening fully, rotate the plate clockwise as far as possible to eliminate any play.
- (3) Make sure the woodruff key is installed in the crankshaft keyway. Line up the

keyway in the magneto rotor with the key and start the rotor onto the shaft. Push the rotor as far as possible by hand, so as to engage the tapered end of the shaft.

- (4) Install the flat washer, lock washer, and hex nut on crankshaft.
  - (5) Secure rotor locking tool to magneto rotor as shown in figure 5-9.
- Using a 1/2-inch socket wrench, tighten the hex nut to secure the magneto rotor.
- (6) Remove rotor locking tool and install air screen, using the same two self-locking nuts.
  - (7) Install starter fan housing as described in paragraph 5-11.

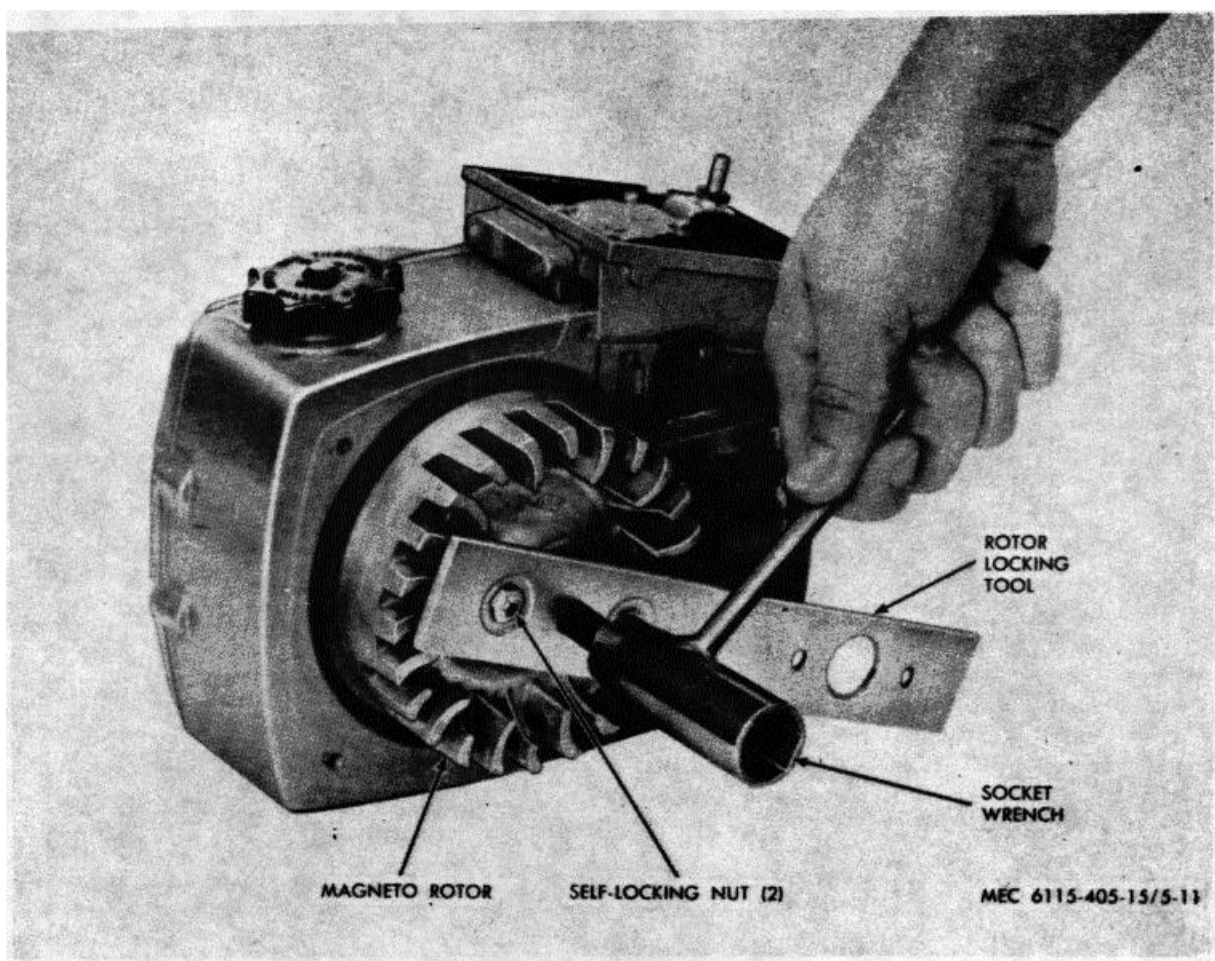

Figure 5-11. Removal of magneto rotor.



**5-14. Carburetor***a. Removal.*

- (1) Remove air cleaner element cover and air cleaner element (fig. 3-3.)
- (2) Remove the screw holding carburetor link connector and throttle shaft extension. Using a pair of pliers, pull the throttle shaft extension straight off the carburetor shaft. (fig. 3-5.)
- (3) Remove cotter pin and free choke rod from carburetor. (fig. 3-5.)
- (4) Disconnect throttle return spring from carburetor throttle lever. (fig. 3-5.) Do not remove throttle return spring clamp.
- (5) Loosen the two 2 1/4-inch long cover bracket screws to free carburetor from carburetor chamber.
- (6) Angle or tilt the carburetor from side to side and disconnect the fuel line from the inlet fitting. Tilt the carburetor and attached parts up at the fuel inlet side and lift it free.

*b. Installation.*

- (1) Place cover bracket assembly in position in front of carburetor and insert two 2 1/4-inch long screws and lock washers.
- (2) Position two carburetor gaskets and heat dam (one gasket on each side of heat dam) behind carburetor and make sure

bracket screws go through proper holes in gasket.

- (3) Angle carburetor and attached parts as necessary and place in position in carburetor chamber. Connect fuel line to inlet fitting.

**Note**

**To facilitate installation of a new fuel line, it is necessary to heat the end of the line in a pot of boiling water until it is soft.**

- (4) Check that carburetor gaskets are properly positioned, and tighten the two 2 1/4-inch long screws.
- (5) Insert throttle return spring in the second hole from the unflanged end of carburetor throttle lever.
- (6) Slide choke rod through outer hole in choke lever and secure with cotter pin. (fig. 3-5.)
- (7) Install throttle shaft extension with the concave cut side of the flat end up. Push throttle shaft extension on until the notch engages the roll pin. Install carburetor link connector and screw over throttle shaft extension. (fig. 3-5.)
- (8) Install air cleaner element and cover.

## CHAPTER 6

## SPECIFIC REPAIR INSTRUCTIONS

## Section I. STARTER FAN HOUSING AND IGNITION PARTS

**6-1. General**

This section contains complete repair instructions for the starter fan housing and ignition parts of the generator set. Tool applications and special procedures are provided where applicable.

**6-2. Disassembly**

Figure 6-1 is a complete exploded view of the subject parts. In general, disassemble in the numerical sequence indicated on figure 61. Special procedures and tool applications are given below: .

a. Refer to paragraph 5-11 for instructions on removing starter fan housing subassembly (4, fig. 6-1).

b. Rotate starter pulley and cup assembly (18) until the pulley slot is aligned with the passage for starter rope (8). Using a pair of long-nose pliers, pull the rope slack into the interior of starter fan housing subassembly (4) while keeping the pulley from turning. Release the tension by unwinding in a counterclockwise direction.

c. Using an Allen wrench, remove socket head screw (19). Lift out starter pulley and cup assembly (18). Unwind and pry out knot of starter rope (8) from the pulley.

d. If starter rope (8) is to be replaced, pry rope retaining insert (5) out of starter handle (6). Cut the rope near the insert and remove the remaining knot end from the insert.

e. Lift out outer spring shield (17). Grasp starter fan housing subassembly (4) and slap it open end down onto a flat surface to remove recoil spring (16).

f. Use rotor locking tool held in place with self-locking nuts (21) as shown in figure 5-9 when removing nut (23, fig. 6-1).

**Note**

**While the tool is in position, loosen socket head screw in generator rotor using a 3/16-inch Allen wrench.**

g. Use rotor locking tool as shown in figure 5-11 when removing magneto rotor (30, fig. 6-1).

**6-3. Inspection and Repair**

a. Clean all parts with an approved cleaning solvent. Dry parts thoroughly. Apply a film of light oil to all exposed ferrous metal parts as a corrosion preventive.

**Note**

**Do not apply oil to magneto and starter parts**

b. Discard breaker point set (39 through 42, fig. 6-1) capacitor (46), felt cam wiper (47), and felt seal (53).

c. Inspect shielded ignition cable (43) and ignition coil (50) for damaged leads, cracked insulation, and other damage. Replace if damaged.

d. Inspect magneto rotor (30) for cracks and other visible damage.

e. Inspect starter rope (8) for worn or frayed condition. Replace if condition is doubtful.

**6-4. Reassembly**

Reassemble parts in reverse of numerical sequence as illustrated on figure 6-1. Note the following:

a. Install a new felt seal (53, fig. 6-1) on the crankshaft.

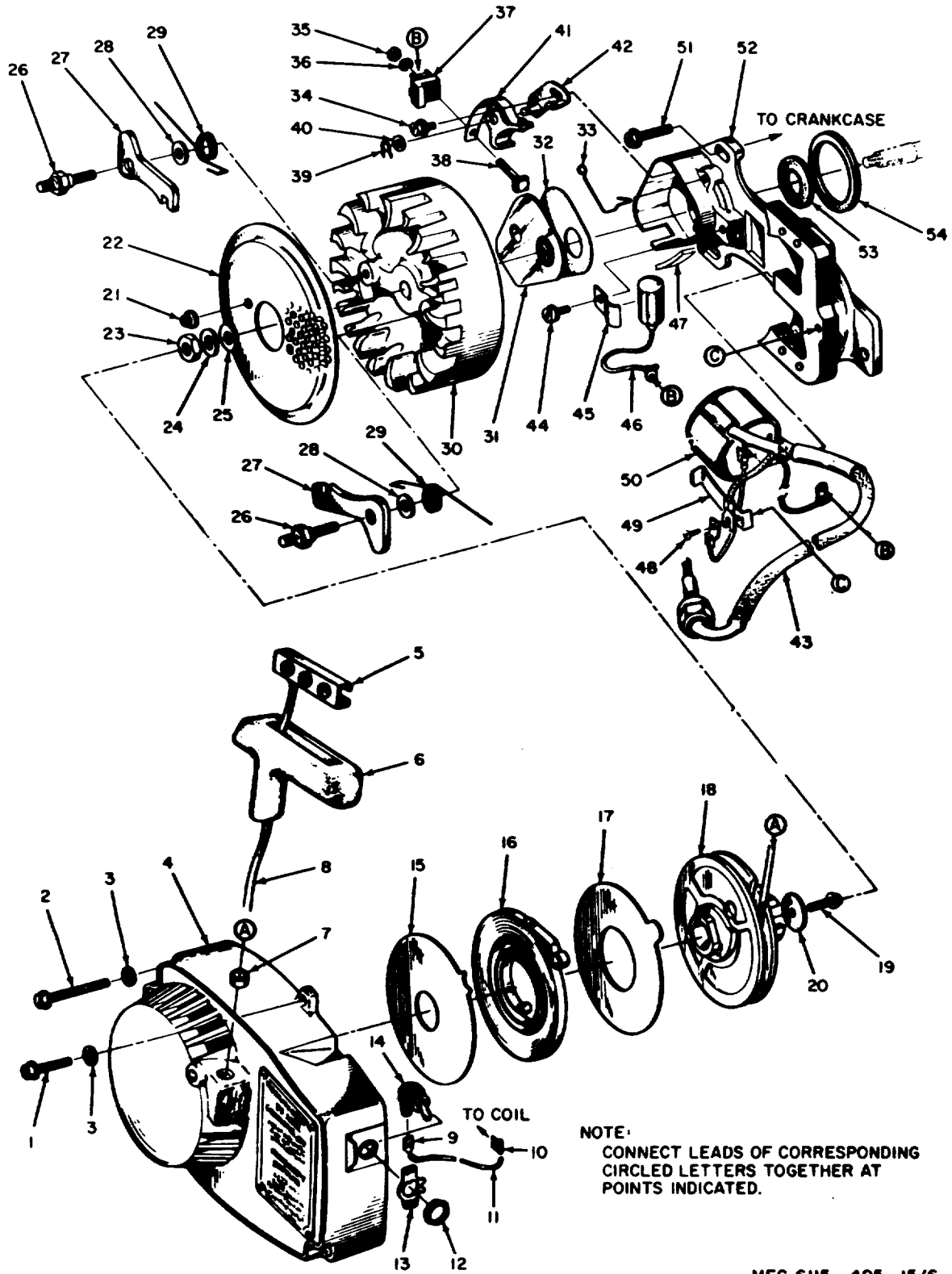

MEC 6115-405-15/6-1

Figure 6-1. Starter fan housing and ignition parts, exploded view.



1	Screw, hex-hd	28	Washer, flat (2)
2	Screw, hex-hd (3)	29	Torsion spring (2)
3	Washer, lock (4)	30	Magneto rotor
4	Starter fan housing subassembly	31	Breaker box cover
5	Rope retaining insert	32	Breaker box cover gasket
6	Starter handle	33	Breaker box cover spring
7	Starter cover bushing	34	Assembled washer screw
8	Starter rope	35	Nut, hex, No.
9	Quick disconnect terminal	36	Washer, lock
10	Quick disconnect terminal	37	Terminal block
11	Electrical lead	38	Terminal stud
12	Nut, hex,	39	Hairpin clip
13	Plate	40	Shim (1 or 2)
14	Toggle switch	41	Breaker arm group
15	Inner spring shield	42	Fixed contact
16	Recoil spring	43	Shielded ignition cable
17	Outer spring shield	44	Captive screw
18	Starter pulley and cup assembly	45	Capacitor clamp
19	Screw, socket-hd	46	Capacitor
20	Washer, flat	47	Felt cam wiper
21	Nut, self-locking (2)	48	Coil ground screw
22	Air screen	49	Coil wedge
23	Nut, hex	50	Ignition coil
24	Washer, lock	51	Screw, hex-hd (3)
25	Washer, flat	52	Stator plate
26	Shouldered stud (2)	53	Felt seal
27	Starter finger (2)	54	Gasket

**Figure 6-1-Continued.**

b. Install a new prelubricated felt cam wiper (47) in the wiper holder in the side wall of the breaker box.

c. Slide ignition coil (50) and coil wedge (49) onto the core of stator plate (52) until the tang of the coil wedge engages the end of the core. Secure coil ground lead and wedge to core with screw (48). Do not tighten screw (48) fully.

d. Wrap lead of capacitor (46) once around primary (black) lead of ignition coil and secure both to terminal stud (38) with nut (35). Make sure primary (black) lead is engaged under raised finger of stator plate to prevent interference with magneto rotor.

e. Install assembled stator plate parts to crankcase with screws (51). Before tightening screws fully, rotate plate clockwise, as far as possible, to remove any play.

f. If shielded ignition cable (43) was removed from ignition coil (50), turn the end of the cable clockwise into the coil until it is secure. Connect ground shield terminal of ignition cable under screw (48) and tighten the screw.

g. Using a 0.015-inch feeler gage, set the breaker point gap. Rotate crankshaft counterclockwise until the breaking edge of the actuating cam is 1/8 inch beyond breaker arm cam follower. Loosen screw (34) and move fixed contact (42) as necessary to set gap.

h. Recheck gap when parts are tightened. Install breaker box cover (31) and gasket (32).

i. When installing starter fingers (27) on magneto rotor (30), make sure the torsion springs (29) are parallel to flat edges of starter fingers. Springs must be located between vanes of magneto rotor (30), and have sufficient tension to hold starter fingers toward center.

j. Position assembled magneto rotor over crankshaft so that keyway lines up with woodruff key in shaft, and start rotor onto shaft.

Push the rotor as far as possible by hand so as to engage the tapered end of the shaft.

k. Install flat washer (25), lockwasher (24), and nut (23) on crankshaft. Using rotor locking tool as shown in figure 5-9 with self-locking nuts (21, fig. 6.1) securing the tool, tighten nut (23) with a 1/2-inch socket wrench.

*l.* Remove rotor locking tool and secure air screen (22) with self-locking nuts (21).

*m.* When installing recoil spring (16), be sure the loop in the spring (at 10 o'clock position) fits over the pin in starter fan housing subassembly (4) and the inside end of the spring points to the left. Apply a light coat of grease to both sides of recoil spring and on starter post. Make sure to install inner and outer spring shields (15 and 17).

*n.* If a new starter rope (8) is used, feed the rope about 12-inches through hole from inside to outside of the starter fan housing subassembly (4).

*o.* Push outside end of rope through the rubber starter handle (6), then through rope retaining insert (5). Tie a simple overhand knot in this end of rope, and pull it back so knot is inside the insert. Push the insert into handle.

*p.* Tie a simple overhand knot on inside end of the rope and crop end close to the knot *q.* Load starter pulley by turning it clockwise 8 turns; locate pulley slot near the rope hole in housing. Hold pulley from turning during time the rope is being attached to pulley in the next step.

**Caution:**

**Never turn spring loaded pulley in a counterclockwise direction as this can cause starter failure. Wind**

**exactly 8 turns tension on pulley recoil spring.**

*r.* While holding pulley under 8 turns tension, insert knot into knot hole at the end of pulley slot, and coax rope through slot. Aline rope to run from the pulley directly to hole in starter fan housing.

*s.* Let go of pulley and allow rope to wind up on the pulley. With starter spring coiled up, the starter handle should be snug against housing with no slack.

*t.* Install ignition switch (14) and secure lead terminals (9 and 10) to switch and ignition coil.

*u.* Holding starter fan housing against the engine with one hand, pull the starter handle out approximately one foot and allow to rewind until the housing fits into register. Install and tighten screws (1 and 2) and internal tooth lock washers (3) using a thin-walled 5/16-inch socket wrench or large screwdriver. Note correct position of shorter (5/8 inch long) screw (1).

**Caution:**

**Fan housing must seat all around to avoid breakage of housing or starter fingers when screws are tightened.**

**Section II GENERATOR**

**6-5. General**

This section contains complete repair instructions for the generator. Tool applications and special procedures are provided where applicable.

**6-6. Disassembly**

Figure 6-2 is a complete exploded view of the generator and related parts. In general, disassemble in the numerical sequence indicated on figure 62. Special procedures and tool applications are given below.

*a.* Refer to paragraph 5-12 for instructions on removing generator parts from drivecase (75, fig. 62).

*b.* Keep crankshaft from turning and remove generator shaft (21) by turning clockwise.

*c.* Use fabricated bearing and seal tool to press needle bearing (19) out of stator mounting plate (18).

**6-7. Inspection and Repair**

*a.* Inspect all parts for visible damage.

*b.* Check that needle bearings (19 and 34, fig. 6-2) roll freely and are smooth running.

*c.* Inspect leads of generator stator (16) for frayed and burned insulation.

**6-8. Reassembly**

Reassemble parts in reverse of numerical sequence as illustrated on figure 62. Note the following:

a. If engine parts (sec. IV) are to be disassembled, do not assemble generator until engine is completely reassembled. Note that instructions for installing crankcase gasket (35, fig. 6-2) and screws (33) are provided in paragraph 6-16.

b. Apply a small amount of grease to needle bearing (19). Use fabricated bearing and seal tool to install needle bearing (19) in stator mounting plate (18).

c. If generator stator (16) was replaced, thread the leads through rubber grommet (17) in stator mounting plate (18), and through rubber grommet (12) in drivecase (75). Be careful not to pinch the leads; secure the stator mounting plate with left-hand side screws (5).

d. Connect stator leads to output connector (9) and secure output connector to junction box (8).

e. Position leads as necessary and secure with cable clamp (11).

f. Secure junction box and stator mounting plate with remaining (right-hand side) screws (5).

g. Aline keyway in generator rotor (4) with keyway in generator shaft (21), and install rotor. Insert machine key (20) from the outside to simplify assembly.

h. When reconnecting new fuel lines only, it is necessary to heat the ends of the lines in a pot of boiling water until they are soft. They can then be easily stretched over the fittings of fuel tank selector valve (62).

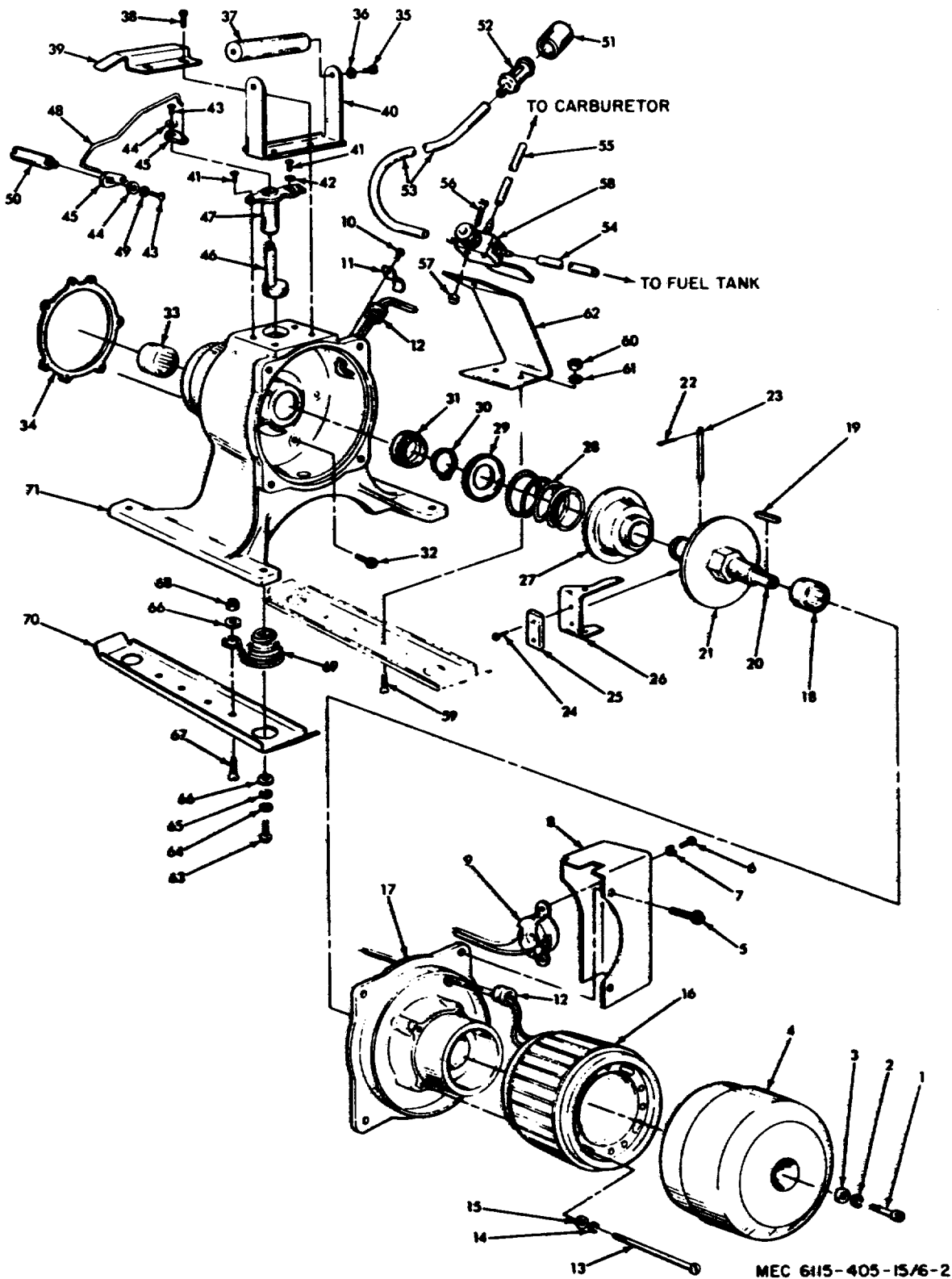

MEC 6115-405-15/6-2

Figure 6-2. Generator, exploded view.

1	Screw	25	Weight	49	Washer
2	Washer	26	Arm	50	Extension
3	Washer	27	Cup	51	Element
4	Rotor	28	Spring	52	Shaft
5	Screw	29	Washer	53	Line Ay
6	Screw	30	Ring	54	Line
7	Washer	31	Seal	55	Line
8	Junction box	32	Screw	56	Screw
9	Connector	33	Bearing	57	Nut
10	Screw	34	Gasket	58	Valve
11	Strap	35	Screw	59	Screw
12	Grommet	36	Washer	60	Nut
13	Screw	37	Grip	61	Washer
14	Washer	38	Screw	62	Bracket
15	Washer'	39	Guard	63	Screw
16	Stator	40	Bracket	64	Washer
17	Plate Ay	41	Screw	65	Washer
18	Bearing	42	Washer	66	Washer
19	Key	43	Screw	67	Screw
20	Shaft	44	Washer	68	Nut
21	Back Plate	45	Connector	69	Spring
22	Pin	46	Cam & Shaft	70	Skid
23	Pin	47	Guide	71	Drive Case
24	Screw	48	Link		

Figure 6-2 -- Continued.

**Section III. CARBURETOR CHAMBER**

**6-9. General**

This section contains complete repair instructions for the carburetor chamber (but not for the carburetor assembly which is covered in Section V). Tool applications and special procedures are provided where applicable.

**6-10. Disassembly**

Figure 6-3 is a complete exploded view of the carburetor chamber section. Disassemble in the numerical sequence indicated on figure 6-3. Note the special procedures provided in paragraph 5-4.

**6-11. Inspection and Repair**

- a. Inspect all parts for visible damage.
- b. Inspect reed (30, fig. 6-3) to be sure it is not cracked, warped, or ragged.
- c. Inspect the surface of carburetor chamber subassembly (25) on which the reed seats. There must be no gouges or wear indicated. It is recommended that screws (27) be discarded and new ones used for assembly.

**6-12. Reassembly**

Reassemble parts in reverse of numerical sequence as illustrated on figure 6-3. Note the following.

- a. Using new screws (27, fig. 6-3), install reed (30), reed spring (29), and reed stop (28) on carburetor chamber subassembly (25).

**Note**

**Be sure there are no chips and burrs on the chamber surface.**

- b. Using screws (24), secure carburetor chamber subassembly (25) to the engine.
- c. Install rubber grommet (26) and insert the fuel line through the grommet.
- d. Place cover bracket assembly (9) in position in front of carburetor assembly (20), and insert two screws (7) and lock washers (8) through the bracket and carburetor assembly.
- e. Position two carburetor gaskets (21) on either side of heat dam (22) behind carburetor assembly (20) and make sure screws go through proper holes in gaskets.
- f. Angle carburetor assembly and attached parts as necessary and place in position in carburetor chamber subassembly (25). Connect fuel line to inlet fitting.

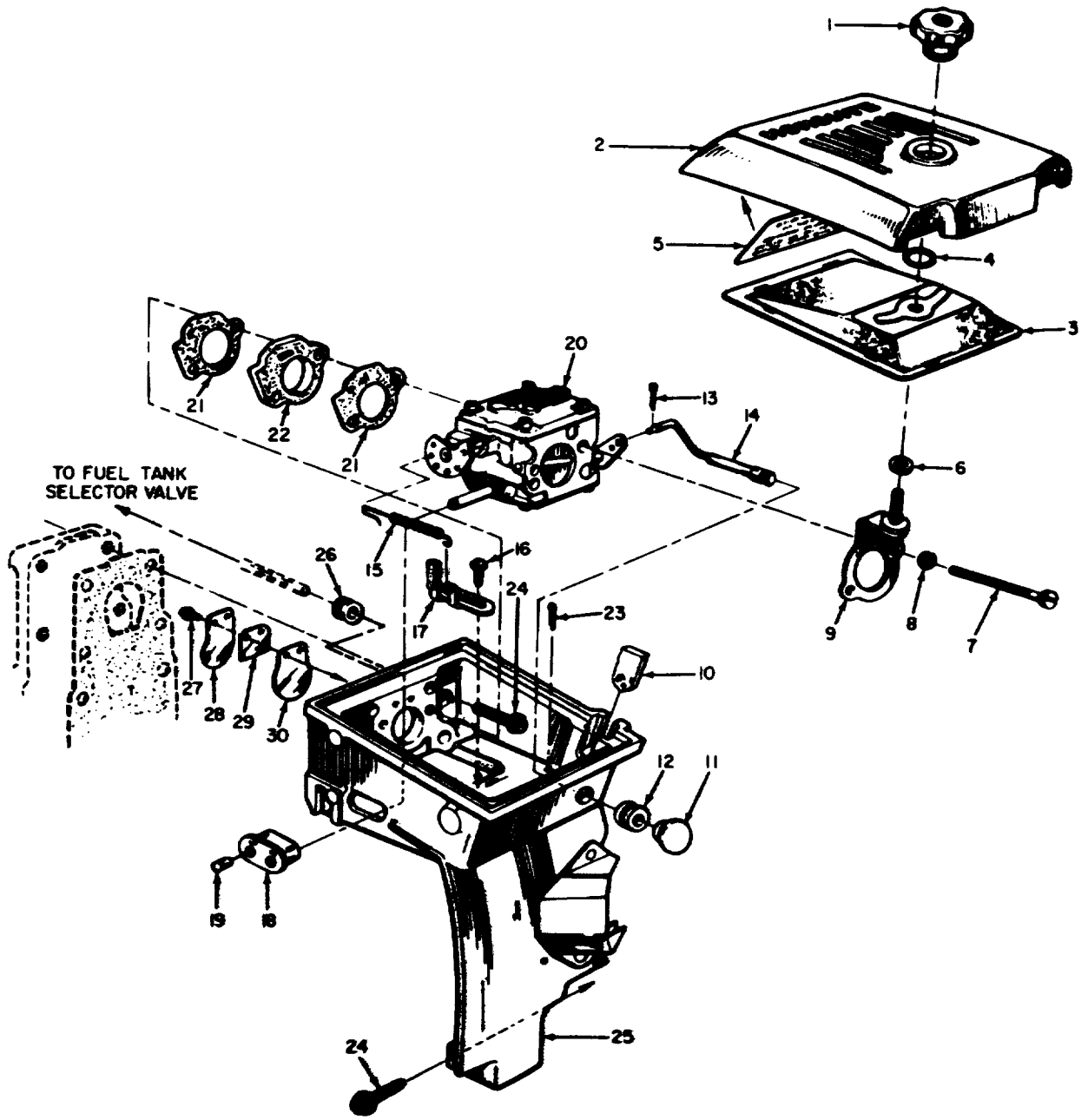

MEC 6115-405-15/6-3

Figure 6-3. Carburetor chamber, exploded view.

1	Captive nut	11	Choke button	21	Carburetor gasket (2)
2	Air cleaner element cover	12	Rubber grommet	22	Heat dam
3	Air cleaner element	13	Cotter pin	23	Cotter pin
4	Retaining ring	14	Choke rod	24	Screw, hex-hd
5	Instruction plate	15	Throttle return spring	25	Carburetor chamber subassembly
6	Gasket	16	Screw, pan-hd	26	Rubber grommet
7	Screw, hex-hd	17	Throttle return spring clamp	27	Screw, pan-hd
8	Washer, lock	18	Rubber grommet	28	Reed stop
9	Cover bracket assembly	19	Rubber plug	29	Reed spring
10	Felt plug	20	Carburetor assembly	30	Reed

Figure 6-3 - continued.

**Note**

**Only if a new fuel line is installed, is it necessary to heat the end of the line in a pot of boiling water until it is soft.**

*g.* Check that carburetor gaskets are properly positioned, and tighten two screws (7).

*h.* If throttle return spring clamp (17) was removed, install with screws (16). Use the impressions made in the clamp as a guide to position the part.

*i.* Connect throttle return spring (15) to the clamp and to the second hole from the unflanged end of carburetor throttle lever as shown on figure 6-3.

*j.* Install rubber grommet (12) and insert choke rod (14) through the grommet. Slide the choke rod through hole in choke lever and secure with cotter pin (13).

*k.* Install the throttle shaft extension with the concave-cut side of the flat end up. Push throttle shaft extension on until the notch engages the roll pin. Secure the linkage as shown in figure 3-5.

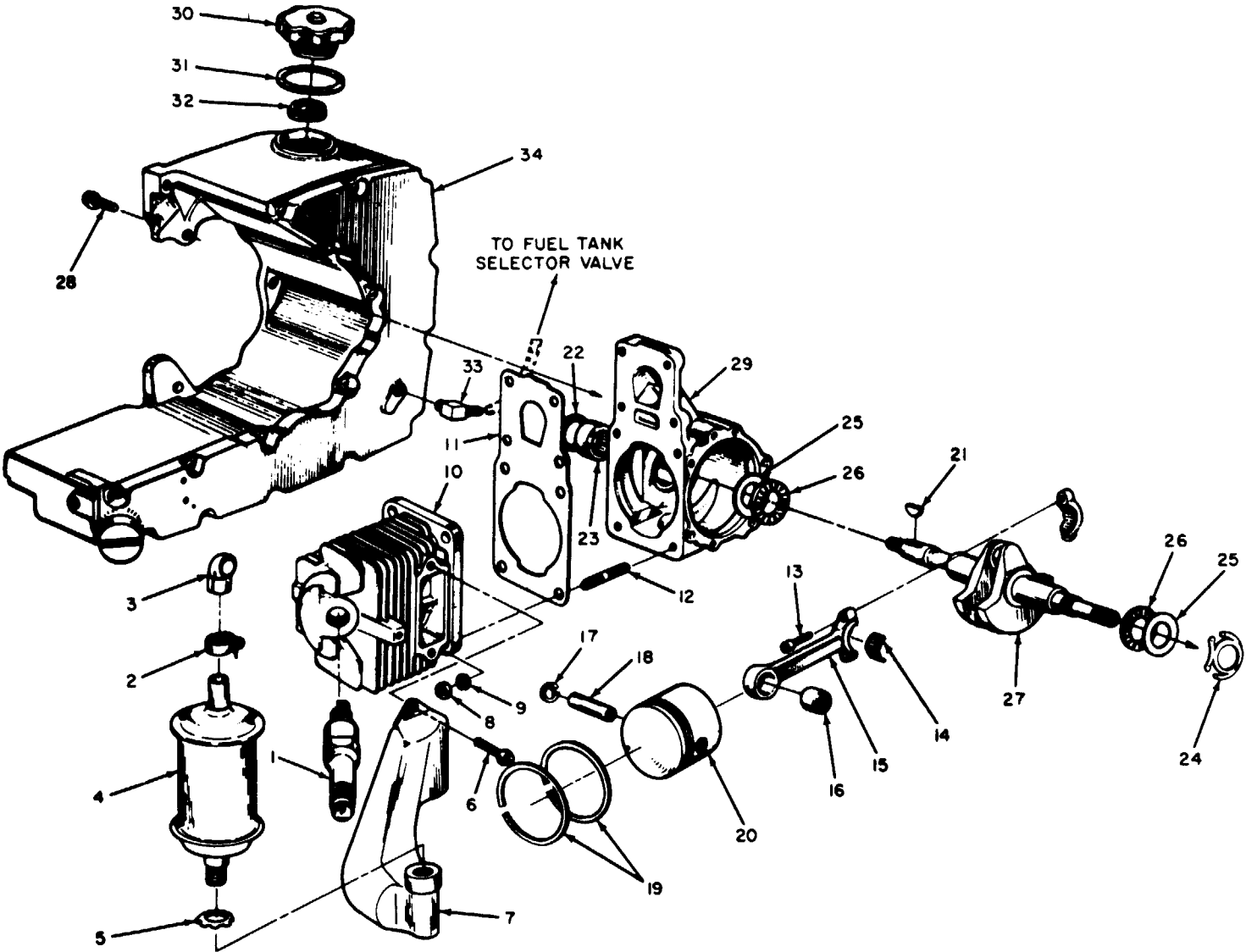

MEC 6115-405-15/6-4

Figure 6-4. Engine, exploded view.



1	Spark plug	13	Screw, cap socket-hd (2)	25	Bearing race (2)
2	Hose clamp	14	Needle rollers (31)	26	Thrust bearing (2)
3	Exhaust elbow	15	Connecting rod	27	Crankshaft
4	Muffler	16	Needle bearing	28	Screw, hex-hd
5	Lock nut	17	Retaining ring	29	Crankcase
6	Screw, hex-hd (2)	18	Piston pin	30	Fuel tank cap
7	Exhaust manifold	19	Piston ring set	31	Fuel cap gasket
8	Nut, hex (4)	20	Piston	32	Relief valve
9	Washer, lock, 1/4 in.	21	Woodruff key	33	Pipe to hose elbow
10	Cylinder	22	Seal	34	Fuel tank
11	Cylinder gasket	23	Needle bearing		
12	Stud (4)	24	Loading spring		

**Figure 6-4-Continued.**

## Section IV. ENGINE

### 6-13. General

This section contains complete repair instruction for the engine parts. Tool applications and special procedures are provided where applicable.

### 6-14. Disassembly

Figure 6-4 is a complete exploded view of the engine section. In general, disassemble in the numerical sequence indicated on figure 64; Special procedures and tool applications are given below:

- a. Use fabricated offset wrench to remove nuts (8, fig. 6-4) from cylinder (10). Remove the cylinder. Pack rags around piston (20) to prevent damage.
- b. Use a 9/64-inch Allen wrench to loosen socket head screws (13). Discard the screws. Remove both halves of connecting rod (15) and all 31 needle rollers. Slide crankshaft (27) straight out of crankcase (29).
- c. Using a pair of retaining ring pliers, remove retaining ring (17) from piston (20).
- d. Insert fabricated piston pin removal tool past the Spiral pin in piston (20) and press or tap out piston pin (18).

#### Caution

**Do not press the tool in too far or the Spiral pin will shear off.**

- e. Starting from the top of the piston (20), carefully expand piston rings (19) to clear the piston, and remove them.
- f. Using fabricated needle bearing assembling tool, press needle bearing (16) out of connecting rod (15).
- g. Using fabricated bearing and seal tool, remove needle bearing (23) and seal (22) from crankcase (29). Insert the longer shouldered end of the tool from inside the crankcase and press the parts out in the direction shown in figure 6-4.

### 6-15. Inspection and Repair

- a. Discard socket head screws (13, fig. 6-4), 31 needle rollers (14), and retaining ring (17) each time they are removed.
- b. Discard seal (22) whenever it is removed from crankcase (29).

c. Inspect and clean or replace spark plug (1) as required. Reset gap to 0.30 inch.

d. Clean and inspect cylinder (10) for worn chrome plating. Inspect cylinder (10), crankshaft (27), and crankcase (29), for cracks, porous spots, and scored sealing surfaces.

e. Inspect needle bearings by trying to separate the needles at one end. If the needles can be separated more than the width of one needle, replace the bearing.

f. Inspect loading spring (24) for damage. Check the height and replace if less than 1/8 inch.

g. Scrape heavy deposits from the top of piston (20) and clean by carefully wire-brushing only the dome area.

#### Caution

**Do not clean varnish-like deposits from piston skirt or side walls of cylinder (10). Use extreme care so as not to scratch polished chrome surfaces.**

h. Using the butt end of a discarded piston ring, carefully clean piston ring grooves in piston (20). Wash the piston in an approved cleaning solvent.

i. Inspect piston rings (19) for wear. Replace if they are scored, have excessively round wear pattern, or have machining marks obliterated.

### 6-16. Reassembly

Reassemble parts in reverse of numerical sequence as illustrated on figure 64. Note the following:

a. Using fabricated bearing and seal tool, install needle bearing (23, fig. 6-4) in crankcase (29). Use the shorter shouldered end of the tool (from the interior of the crankcase), pressing against the lettered side of the needle bearing.

b. Using a new seal (22) greased to protect it from damage, place the seal on the long end of fabricated seal assembling plug with the open end of the seal facing needle bearing (23). Install the seal from the outer surface of crankcase (29).

c. Install thrust bearing (26) and bearing race (25) on each end of crankshaft (27). Install loading spring (24) on the generator end of the crankshaft with the open feet of the spring inward.

d. Making sure woodruff key (21) is not in place, install fabricated seal assembling sleeve with beveled end out onto the key end of crankshaft (27). Lubricate the sleeve and end of the crankshaft to prevent damage.

e. Carefully insert crankshaft (27) into crankcase (29). Remove seal assembling sleeve and install it on the opposite end of the crankshaft. Lubricate the sleeve and shaft as in step d. Install woodruff key (21) in keyway of crankshaft (27).

f. Place crankcase gasket (35, fig. 6-2) carefully in position and secure drivecase (75) to crankcase (29, fig. 6-4) with five new Loctite-prepared screws (33, fig. 6-2). Note that the length of these screws is critical. Be sure proper screws are used.

g. Remove fabricated seal assembling sleeve.

h. Using fabricated needle bearing assembling tool and pressing only on the lettered side of needle bearing (16, fig. 6-4), install bearing in connecting rod.(15).

i. Carefully install piston ring set (19) on piston (20) with the open ends adjacent to the piston ring retaining pin.

j. Insert connecting rod (15) into piston (20). Use a 3/16-inch diameter rod to press on the open end of piston pin (18) and press the pin into the piston.

k. Using a pair of retaining ring pliers, install new retaining ring (17) into the groove in piston (20) with the square edge of the ring facing outward. Rotate the ring to be sure it is installed properly, and align the open end parallel with the connecting rod (either up or down).

l. Using bearing grease or beeswax to lay out new needle rollers, lay out one strip of 16 rollers and one of 15 rollers. Insert one strip of rollers into each connecting rod half.

m. Bend a strip of metal or wire to hold the lower half of connecting rod (15) in position under the shaft journal. Make sure piston pin retaining ring is toward the magneto end of the engine. Align the match marks on connecting rod halves. Position the upper half of connecting rod and secure with new socket head screws (13). Tighten screws to a torque of 55 to 61 pound-inches. Rotate shaft to check that all needle rollers are in position and the bearing turns smoothly.

n. Position cylinder gasket (11) in place so that holes are aligned.

o. Apply some oil to piston (20) and interior of cylinder (10). If a piston ring compressor is not available, use a strip of metal bent to 1 3/8-inch diameter to compress the piston rings and install cylinder (10) straight down over the piston with the exhaust port facing the generator end. Remove the compressor strip and secure cylinder to crankcase studs, with nuts (8) and lockwashers (9). Use fabricated offset wrench to tighten nuts.

## Section V. CARBURETOR ASSEMBLY

### 6-17. General

This section contains complete repair instructions for the carburetor assembly.

### 6-18. Disassembly

Figure 6-5 is a complete exploded view of the carburetor assembly. Disassemble in the numerical sequence indicated on figure 6-5.

### 6-19. Inspection and Repair

a. To clean carburetor parts, use approved solvents except an diaphragms and gaskets.

b. Blow out channels in body (30, fig. 6-5) with compressed air.

c. Inspect fuel pump diaphragm (5) and diaphragm (10) for breaks or punctures. Replace if damaged.

d. In extreme cases of clogged channels -and discharge ports, it may be necessary to remove expansion plug (16). If required, drill a 1/16-inch hole through the plug just deep enough to break through the plug. Carefully pry out the plug and discard. Clean channels and discharge ports. Install a new plug by placing the plug in well, convex side up, and flatten with a tool slightly larger than the plug.

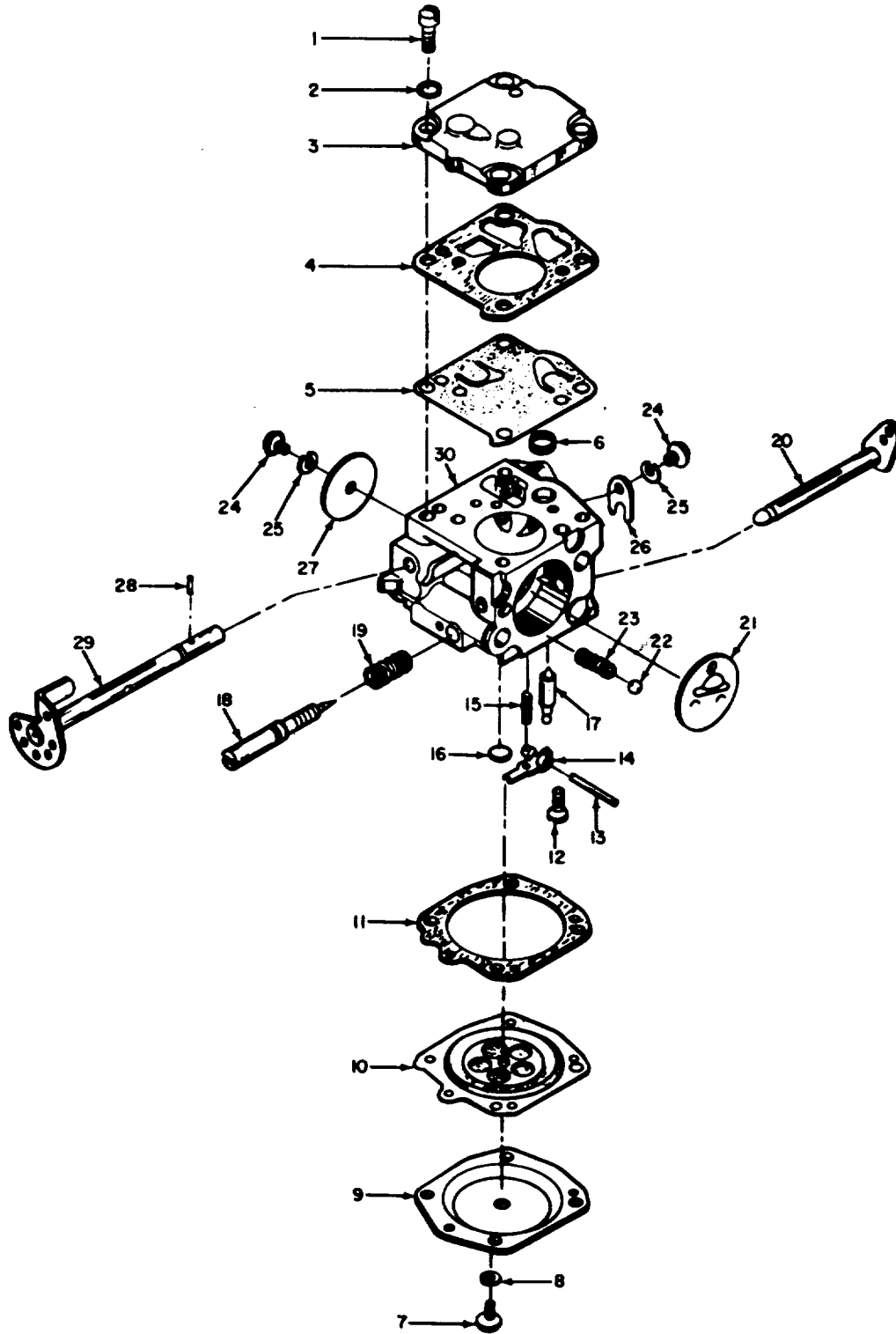

MEC 6115-405-15/6-5

Figure 6-5. Carburetor assembly, exploded view.

1	Screw, fillister-hd (4)	11	Diaphragm gasket	21	Choke shutter
2	Washer, lock (4)	12	Screw, thread cutting	22	Ball bearing
3	Pump cover	13	Fulcrum pin	23	Compression spring
4	Fuel pump gasket	14	Inlet valve control lever	24	Screw, round-hd (2)
5	Fuel pump diaphragm	15	Compression spring	25	Washer, lock (2)
6	Screen	16	Expansion plug	26	Throttle shaft clip
7	Screw, round-hd (4)	17	Inlet needle	27	Throttle shutter
8	Washer, lock (4)	18	Main adjustment screw	28	Spring pin
9	Diaphragm cover	19	Compression spring	29	Throttle shaft and lever
10	Diaphragm	20	Choke shaft and lever	30	Body

**Figure 6-5-Continued.**

**6-20. Reassembly**

Reassemble in the reverse of numerical sequence as illustrated on figure 6-5. Note-the following:

- a. Be sure diaphragm (10, fig. 6-5) and fuel pump diaphragm (5) are installed correctly. Locate the parts on the cast pins in body (30). Tighten screws evenly.
- b. When installing inlet valve control lever (14) and compression spring (15), check that the spring rests in the well of body (30) and is located on the dimple of the lever. Do not stretch the spring. The lever is properly set when flush with the floor of the diaphragm chamber. If diaphragm end of lever is low, pry up. If lever is high, depress diaphragm end and push on needle for proper adjustment.

**APPENDIX A**

**REFERENCES**

**A-1. Painting**

TM 9-213      Painting Instructions for Field Use.

**A-2. Preventive Maintenance**

TM 38-750      Army Equipment Record Procedures.

**A-3. Field Maintenance**

TM 5-764      Electric Motor and Generator Repair.

**A-4. Supply Publications**

C-9100-IL      Petroleum, Petroleum-Base Producer and Related Materiel.

**APPENDIX B  
BASIC ISSUE ITEMS LIST AND MAINTENANCE  
AND OPERATING SUPPLIES**

**Section I. INTRODUCTION**

**B-1. Scope**

This appendix lists items which accompany the generator set or are required for installation, operation, or operator's maintenance. Section II lists the accessories, tools, and publications required for the maintenance and operation by the operator, initially issued or authorized with the equipment. Section III lists the maintenance and operating supplies required for initial operation.

**B-2. Explanation of Columns**

The following provides an explanation of columns in the tabular list in section II:

a. Source, Maintenance and Recoverability Codes (Column 1).

- (1) Source code, column 1a, indicates the selection status and source for the listed item. Source codes are:

Code	Explanation
P	Applies to repair parts which are stocked in or supplied from the GSA/DSA Army supply system, and authorized for use at indicated maintenance categories.
M	Applied to repair parts which are not procured or stocked but are to be manufactured at indicated maintenance categories.
X2	Applied to repair parts which are not stocked. The indicated maintenance category requiring such repair parts will attempt to obtain them through cannibalization. If not obtainable through cannibalization, such repair parts will be requisitioned with supporting justification through normal supply channels.

- (2) Maintenance code, column 1b, indicates the lowest category of maintenance authorized to install the listed item. The maintenance level code is:

Code	Explanation
O	Organization maintenance (operator/crew)

- (3) Recoverability code, column 1c, indicates whether unserviceable items should be returned for recovery or salvage. Items not coded are expendable. Recoverability codes are:

Code	Explanation
R	Applied to repair parts and assemblies which are economically repairable at DSU and GSU activities and are normally furnished by supply on an exchange basis.
T	Applied to high dollar value recoverable repair parts which are subject to special handling and are issued on an exchange basis. Such repair parts are normally repaired or overhauled at depot maintenance activities.
U	Applied to repair parts specifically selected for salvage by reclamation units because of precious metal content, critical materials, high dollar value reusable casings and castings, etc.

b. Federal Stock Number, column 2, indicates the Federal stock number for the item.

c. Description, column 3, indicates the Federal item name and any additional description required. A five-digit manufacturer's or other service code is shown in parentheses followed by the manufacturer's part number. Repair

parts quantities included in kits, sets, and assemblies that differ from the actual quantity used in the specific item are listed in parentheses following the repair part name.

d. Unit of Issue, column 4, indicates the unit used as a basis for issue, e.g., ea, pr, ft, yd, etc.

e. Quantity Incorporated in Unit Pack, column 5, indicates the actual quantity contained in the unit pack.

f. Quantity Incorporated in Unit, column 6, indicates the quantity of the item used on the equipment.

g. Quantity Authorized, column 7, indicates the total quantity of an item required to be on hand and necessary for operation and maintenance of the equipment. Items to be requisitioned as required are indicated by an asterisk.

h. Illustration, column 8.

- (1) Figure Number, column 8a, indicates the figure number of the illustration in which the item is shown.
- (2) Item or Symbol Number, column 8b, indicates the callout number used to reference the item in the illustration.

**B-3. Explanation of Columns Contained in Section III**

a. *Item.* This column contains numerical sequence item numbers assigned to each component application to facilitate reference.

b. *Component Application.* This column identifies the component application of each maintenance or operating supply item.

c. *Federal Stock Number.* The Federal stock number will be shown in this column and will be used for requisitioning purposes.

d. *Description.* The item and a brief description are shown.

e. *Quantity Required for Initial Operation.* This column lists the quantity of each maintenance or operating supply item required for initial operation of the equipment.

f. *Quantity Required for 8 Hours Operation.* Quantities listed represent the estimated requirements for an average eight hours of operation.

**B-4. Federal Supply Code**

29201 Homelite Division of Textron, Inc.  
Port Chester, N.Y.

**SECTION II  
BASIC ISSUE ITEMS LIST**

(1) Source Maint. & Recov. code			(2)  Federal Stock No.	(3)  Description Issue	(4)  Unit of Issue	(5)  Qty. Inc. in Unit Pack	(6)  Qty. Inc in Unit	(7)  Qty. Auth	(8) Illustration	
(A) S	(B) M	(C) R							(A) Fig. No.	(B) Item or Sym No.
P	O		7510-889-3494 7520-559-9618	GROUP 31-Basic Is Items, Manufacturer Installed						
P	O			3100-Basic Items Manufacturer or Depot Installed	EA	1				
				BINDER: equipment log book	EA	1				
P	O			CASE: maintenance and operational manuals; cotton duck, water repel- lent, mildew-resistant						
				CASE ASSEMBLY: carrying (29201) A6544	EA	1				
				DEPARTMENT OF THE ARMY: operator, organizational, direct and general support and depot maintenance manual including repair part and special tools list TM 5-6115-405-15	EA	1				



(1) Source Maint. & Recov. code			(2) Federal Stock No.	(3) Description Issue	(4) Unit of Issue	(5) Qty. Inc. in Unit Pack	(6) Qty. Inc in Unit	(7) Qty. Auth	(8) Illustration	
(A) S	(B) M	(C) R							(A) Fig. No.	(B) Item or Sym No.
P	O		2990-978-7302	HOSE ASSEMBLY: auxiliary fuel (29201) A54510	EA	1		1		
P	O			ROPE ASSEMBLY: engine starting (29201) 58806 GROUP 32-Basic Issue Items, Troop Installed 3200-Basic Issue Items Troop Installed or Authorized	EA	1		1		
P	O		5925-243-5861	CLAMP: electrical ground rod 1/2" to 1" diameter	EA	*		1		
P	O		5120-223-7396	PLIERS: slip joint, straight nose w/cutter 6 in., length	EA	*		1		
P	O		5975-642-8937	ROD: ground 9 ft. length, 5/8" dia. cone point, 3 sections	EA	*		1		
P	O		5120-293-3169	SCREWDRIVER: flat tip, tip 5/16" wide blade 6" length	EA	*		1		
P	O		6145-189-6695	WIRE ELECTRICAL: ground No. 6 AWR	EA	*		10		
P	O		5120-240-5328	WRENCH: open end: adjustable 15/16" jaw opening 8" length	EA	*		1		

Item	Component application	Source of supply	Federal stock No.	Description	Quantity required For initial operation	Quantity required For 8 hours operation	Notes
1	0101-Crankcase (1)			Oil lubricating 1 qt. can as follows OE-30 (SAE-30)	1/4 pint		(1) includes quantity of oil to be mixed with fuel system as follows: 1/4 pint or (4) ounces to 1 gallon of gasoline. See FSC C9100-IL additional data for requisitioning procedure, See LO 5-6115-406-15 for grade application and replenishment interval
2	0306-Fuel Tank (2)	10	9131-160-1818	Fuel, gasoline bulk as follows Automotive, combat 91A	18 ounces		(2) Tank capacity Average fuel consumption is 1/10 gallon per hour of continuous operation

**APPENDIX C  
MAINTENANCE ALLOCATION CHART**

---

**Section I. INTRODUCTION**

**C-1. General**

a. This section provides a general explanation of all maintenance and repair functions authorized at various maintenance levels.

b. Section II designates overall responsibility for the performance of maintenance operations on the identified end item or component. The implementation of the maintenance tasks upon the end item or component will be consistent with the assigned maintenance operations.

c. Section III lists the special tools and test equipment required for each maintenance operation as reference from section II.

d. Section IV contains supplemental instructions, explanatory notes and/or illustrations required for a particular maintenance function.

**C-2. Explanation of Columns in Section II**

a. *Functional Group Number.* The functional group is a numerical group set up on a functional basis. The applicable functional grouping indexes (obtained from TB 750-93 1, Functional Grouping Codes) are listed on the Maintenance Assignment in the appropriate numerical sequence. These indexes are normally set up in accordance with their function and proximity to each other.

b. *Component Assembly Nomenclature.* This column contains a brief description of the components of each functional group.

c. *Maintenance Functions.* This column lists the various maintenance functions (A through K) and indicates the lowest maintenance category authorized to perform these operations. The symbol designations for the various maintenance categories are as follows:

- C -- Operator or crew
- O -- Organizational maintenance
- F -- Direct support maintenance
- H -- General support maintenance
- O -- Depot maintenance

The maintenance functions are defined as follows:

- A- Inspect: Verify serviceability and detect incipient electrical or mechanical failure by close visual examination.
- B- Test: Verify serviceability and detect incipient electrical or mechanical failure by measuring the mechanical or electrical characteristics of the item and comparing those characteristics with authorized standards. Tests will be made commensurate with test procedures and with calibrated tools and/or test equipment referenced in the Maintenance Assignment.
- C- Service: Operations required periodically to keep the item in proper operating condition, i.e., to clean, preserve, drain, paint, and replenish fuel, lubricants, hydraulic, and deicing fluids, or compressed air supplies.
- D- Adjust: Regulate periodically to prevent malfunction. Adjustments will be made commensurate with adjustment procedures and associated equipment adjustment specifications.
- E- Align: Adjust two or more components of an electrical or mechanical system so that their functions are properly synchronized or adjusted.
- F- Calibrate: Determine, check, or rectify the graduation of an instrument, weapon, or weapons system or components of a weapons system.

- G- Install: Remove and install the same item for service or when required for the performance of other maintenance operations.
- H- Replace: Substitute serviceable components, assemblies and subassemblies for unserviceable counterparts.
- I- Repair: Restore to a serviceable condition by replacing unserviceable parts or by any other action required using available tools, equipment and skills, including welding, grinding, riveting, straightening, adjusting and facing.
- J- Overhaul: Restore an item to a completely serviceable condition (as prescribed by serviceability standards developed and published by the commodity commands) by employing techniques of "Inspect and Repair Only as Necessary" (IROAN). Maximum use of diagnostic and test equipment is combined with minimum disassembly during overhaul. "Overhaul" may be assigned to any level of maintenance except organizational, provided the time, tools, equipment, repair parts authorization, and technical skills are available at that level. Normally, overhaul as applied to end items, is limited to depot maintenance level.
- K- Rebuild: Restore to a condition comparable to new by disassembling to determine the condition of each component part and reassembling using serviceable, rebuilt, or new assemblies, subassemblies, and parts.
- d. *Reference Note.* This column, subdivided into columns L and M, is provided for referencing the Special Tool and Test Equipment

Requirements (sec. III) and Remarks (sec. IV) that may be associated with maintenance functions (sec. II).

**C-3. Explanation of Columns in Section III**

a. *Reference Code.* This column consists of a number and a letter separated by a dash. The number references the T&TE requirements column on the Maintenance Assignment. The letter represents the specific maintenance function the item is to be used with. The letter is representative of columns A through K on the Maintenance Assignment.

b. *Maintenance Category.* This column shows the lowest level of maintenance authorized to use the special tool or test equipment.

c. *Nomenclature.* This column lists the name or identification of the tool or test equipment

d. *Tool Number.* This column lists the manufacturer's code and part number, or Federal stock number of tools and test equipment.

**C-4. Explanation of Columns in Section IV**

a. *Reference Code.* This column consists of two letters separated by a dash, both of which are references to section II. The first letter references column M and the second letter references a maintenance operation, columns A through K.

b. *Remarks.* This column lists information pertinent to the maintenance operation being performed, as indicated on the Maintenance Assignment section II.

**Section II. MAINTENANCE ASSIGNMENT**

GROUP FUNCTION NUMBER	COMPONENT ASSEMBLY NOMENCLATURE	MAINTENANCE FUNCTIONS									NOTE REFERENCE			
		A	B	C	D	E	F	G	H	I	J	K	L	M
		INSPECT	TEST	SERVICE	ADJUST	ALIGN	CALLIBRATE	INSTALL	REPLACE	REPAIR	OVERHAUL	REBUILD	TOOLSEQUIPMENT	REMARKS
01	ENGINE													
0100	Engine Assembly													
	Engine assembly, gasoline.....	C	O	C	..	..	..	..	F	F	F	..	..	A
0101	Crankcase, Block Cylinder Head													
	Crankcase .....	..	..	..	..	..	..	..	F					

GROUP FUNCTIONAL NUMBER	COMPONENT ASSEMBLY NOMENCLATURE	MAINTENANCE FUNCTIONS									NOTE REFERENCE			
		A	B	C	D	E	F	G	H	I	J	K	L	M
		INSPECT	TEST	SERVICE	ADJUST	ALIGN	CALIBRATE	INSTALL	REPLACE	REPAIR	OVERHAUL	REBUILD	TOOLSEQUIPMENT	REMARKS
0102	Cylinder.....	..	..	..	..	..	..	..	F					
	Gasket, cylinder.....	..	..	..	..	..	..	..	F					
0103	Crankshaft													
	Crankshaft.....	..	..	..	..	..	..	..	F					
	Bearing.....	..	..	..	..	..	..	..	F					
	Seals and gaskets.....	..	..	..	..	..	..	..	F					
0104	Flywheel Assembly													
	Flywheel.....	..	..	..	..	..	..	..	F					
0107	Pistons, Connecting Rods													
	Pistons.....	..	..	..	..	..	..	..	F					
	Rings.....	..	..	..	..	..	..	..	F					
0108	Rod assembly, connecting.....	..	..	..	..	..	..	..	F					
	Engine Starting System													
0301	Starter Recoil.....	..	..	..	..	..	..	..	O	O				
	Manifolds													
0304	Manifold Exhaust.....	..	..	..	..	..	..	..	O					
	FUEL SYSTEM													
0306	Carburetor													
	Carburetor.....	..	..	..	O	..	..	..	F	F				
0308	Air Cleaner													
	Filter.....	..	..	O	..	..	..	..	O					
0309	Tanks, lines, fittings													
	Tank.....	..	..	O	..	..	..	..	F	F				
0312	Hose.....	..	..	..	..	..	..	..	O					
	Valve, fuel 3-way.....	..	..	..	..	..	..	..	O					
04	Engine Speed Governor and Controls													
	Governor assembly.....	..	..	..	O	..	..	..	F	F				
05	Spring.....	..	..	..	..	..	..	..	O					
	Rod control.....	..	..	..	..	..	..	..	O					
0605	Fuel Filter													
	Strainer.....	..	..	O	..	..	..	..	O					
0607	Throttle or Choke Controls													
	Choke, control assembly.....	..	..	..	..	..	..	..	O					
15	EXHAUST SYSTEM													
	Muffler and Pipes													
06	Muffler.....	..	..	O	..	..	..	..	O	--	--	--	B	
	Tail pipe.....	..	..	..	..	..	..	..	O					
0605	COOLING SYSTEM													
	Cowling, Deflectors, Air Duct, Shrouds													
0607	Shroud.....	..	..	..	..	..	..	..	F					
	ELECTRICAL SYSTEM (ENGINE)													
0605	Ignition Components													
	Magneto, ignition.....	..	..	..	..	..	..	..	F					
0607	Contact set, ignition.....	..	..	..	..	..	..	..	F					
	Lead, electrical, ignition.....	..	..	..	..	..	..	..	F					
15	Spark plug.....	..	..	O	O	..	..	..	O					
	Instrument or Engine Control Panel													
15	Switch toggle.....	..	..	..	..	..	..	..	F					
	FRAME, TOWING ATTACHMENTS and DRAW BARS													
15	Frame Assembly													
	Skids.....	..	..	..	..	..	..	..	O					

GROUP FUNCTIONAL NUMBER	COMPONENT ASSEMBLY NOMENCLATURE	MAINTENANCE FUNCTIONS									NOTE REFERENCE			
		A	B	C	D	E	F	G	H	I	J	K	L	M
		INSPECT	TEST	SERVICE	ADJUST	ALIGN	CALIBRATE	INSTALL	REPLACE	REPAIR	OVERHAUL	REBUILD	TOOLS AND EQUIPMENT	REMARKS
18	Springs, shock .....	..	..	..	..	..	..	..	O					
1808	Handle lifting .....	..	..	..	..	..	..	..	O					
	BODY, CAB, HOOD, and HULL													
	Stowage Racks, Boxes, Carrying Cases													
22	Carrying case .....	..	..	..	..	..	..	..	O	O				
	BODY, CHASSIS or HULL, and													
	ACCESSORY ITEMS													
2210	Data Plates .....	..	..	..	..	..	..	..	O					
	Plates (C.O.E.) .....	..	..	..	..	..	..	..	F					
40	ELECTRIC MOTORS and GENERATORS													
4000	Generator Assembly													
	Generator assembly .....	..	F	..	..	..	..	..	F	F				
4001	Rotor Assembly													
	Rotor assembly .....	..	F	..	..	..	..	..	F	F	F			
4002	Stator Assemblies													
	Stator assembly .....	..	F	..	..	..	..	..	F	F				
4018	Terminal Blocks, Junction Boxes													
	Connector receptacle .....	..	..	..	..	..	..	..	F					

**Section III. SPECIAL TOOL AND SPECIAL TEST EQUIPMENT REQUIREMENTS**

Reference code	Maintenance level	Nomenclature	Tool number
No special tool or special test equipment required.			

**Section IV. REMARKS**

Reference code	Remarks
A-B	Test includes engine operation and compression.
B-C	Service includes cleaning out carbon.

**APPENDIX D  
ORGANIZATIONAL, DIRECT, AND GENERAL SUPPORT  
AND DEPOT MAINTENANCE REPAIR PARTS LIST**

**Section I. INTRODUCTION**

**D-1. Scope**

This manual contains a list of repair parts required for the performance of organizational, direct support, general support, and depot maintenance of the generator set.

**D-2. General**

This repair parts list is divided into four principal sections.

a. Section II, Prescribed Load Allowance List (PLA), is a consolidated listing of repair parts quantitatively allocated for initial stockage at the organizational level. This is a mandatory minimum stockage allowance.

b. Section III, Repair Parts List, is a list of repair parts authorized for the performance of maintenance at the organizational level.

c. Section IV, Repair Parts List, is a list of repair parts authorized for the performance of maintenance at the direct support, general support, and depot level.

**D-3. Explanation of Columns**

The following provides an explanation of columns in the tabular lists.

a. Source, Maintenance, and Recoverability Codes.

(1) Source Code indicate the selection status and source for the listed item. Source codes used are:

Code	Explanation
P	Applied to repair parts which are stocked in or supplied from DSA/GSA or Army supply system, and authorized for use at indicated maintenance categories.

Code	Explanation
X1	Applied to repair parts which are not procured or stocked, the requirement for which will be supplied by use of the next higher assembly or components.

X2 Applied to repair parts which are not stocked. The indicated maintenance category requiring such repair parts will attempt to obtain them through cannibalization; if not obtainable through cannibalization, such repair parts will be requisitioned with supporting justification through normal supply channels.

(2) Maintenance Code indicates the lowest category of maintenance authorized to install the listed item. The maintenance level codes are:

Code	Explanation
O	Organizational maintenance
F	Direct support maintenance
H	General support maintenance
D	Depot maintenance

(3) Recoverability Code indicates whether unserviceable items should be returned for recovery or salvage. Items not coded are expendable. Recoverability codes are:

Code	Explanation
R	Applied to repair parts and assemblies which are economically repairable at DSU and GSU activities and normally are furnished by supply on an exchange basis.
T	Applied to high dollar value recoverable repair parts which are subject to special handling and are issued on an exchange basis. Such repair parts normally are repaired or overhauled at depot maintenance activities.

b. Federal Stock Number indicates the Federal stock number for the item.

c. Description column indicates the Federal item name and brief description of the item. A five-digit manufacturer's or other service code is shown in parentheses followed by the manufacturer's part number. Repair parts quantities included in kits, sets, and assemblies that differ from the actual quantity used in the specific item, are listed in parentheses following the repair part name.

d. Unit of Issue indicates the unit used as a basis of issue, e.g., ea, pr, ft, yd, etc.

e. Quantity Incorporated in Unit Pack indicates the actual quantity contained in the unit pack.

f. Quantity Incorporated in Unit indicates the actual number of parts used in the application. A zero is shown when components of kits or sets are listed that are not applicable to the specific end item.

g. Fifteen-Day Organizational Maintenance Allowance.

- (1) The allowance columns are divided into four subcolumns. Indicated in each subcolumn is the quantity of items authorized for the number of equipments supported. Items authorized for use as required but not for initial stockage are identified with an asterisk in the allowance column.
- (2) The quantitative allowances for organizational level of maintenance represent one initial prescribed load for a 15-day period for the number of equipments supported. Units and organizations authorized additional prescribed loads will multiply the number of prescribed loads authorized by the quantity of repair parts reflected in the appropriate density column to obtain the total quantity of repair parts authorized.
- (3) Items identified by an asterisk may be requisitioned as required. Subsequent changes and/or additions to allowances will be limited to the provisions of AR 735-35. The range of items authorized will be made by this Command based upon engineering experience, demand data, or TAERS information.

(4) Allowances are based on 1,000 hours of operation per year.

h. Thirty-Day DS/GS Maintenance Allowance.

- (1) The allowance columns are divided into three subcolumns. Indicated in each subcolumn is the quantity of items authorized for a number of equipments supported. Items authorized for use as required but not for initial stockage are identified with an asterisk in the allowance column.
- (2) The quantitative allowances for DS/GS levels of maintenance will represent initial stockage for a 30-day period for the number of equipments supported.

i. One-Year Allowances Per 100 Equipments/Contingency Plating Purposes indicates the quantity of items required for distribution and contingency planning purposes.

j. Depot Maintenance Allowance Per 100 Equipments indicates the total quantity of items recommended for depot maintenance of 100 equipments. Items recommended for immediate use only are identified with an asterisk in the allowance column.

k. Illustration.

(1) Figure Number indicates the figure number of the illustration in which the item is shown.

(2) Item or Symbol Number indicates the callout number used to reference the item in the illustration.

#### D-4. Instructions for Locating Repair Parts

a. When Federal Stock Number or manufacturer's part number is unknown.

- (1) *First.* Using the index of contents, determine the functional group or subgroup, i.e., engine, engine assembly, transmission, transmission assembly, within which the repair part belongs. Locate the appropriate page in the manual and identify the part.
- (2) *Second.* Locate the repair part and the illustration figure and item



number as shown in the last two columns of the repair parts listing.

- (3) Third. Identify the repair part on the illustration.

b. When Federal Stock Number or manufacturer's part number is known.

- (1) *First.* Use the index to locate the Federal Stock Number or manufacturer's part number. This index is arranged in alphameric sequence cross-referenced to page number and manufacturer's code.
- (2) *Second.* Refer to the appropriate page in the parts listing. Locate the repair part and the illustration figure and item number as shown in the last two columns of the parts listing.

**D-5. Abbreviations**

cont.....	continued
ft .....	foot (feet)
hd .....	head
in.....	inches (es)
lg .....	length (long)
mtg .....	mounting (s)
No.....	number (s)
rd .....	round
thd .....	thread

**D-6. Index of Federal Supply Codes**

Code	Manufacturers
00818.....	Phelon R. E. Co. Inc.
11583.....	Champion Spark Plug Co.
29201.....	Homelite Division of Textron
39317.....	McGill Mfg. Co. Inc.
60380.....	Torrington Co. The
70485.....	Atlantic India Rubber Works Inc.
74284.....	Skydyne Inc.
78480.....	Tillotson
79136.....	Waldes Kohinoor Inc.
79575.....	Wico Electric Co.
92830.....	Wallace Barnes Div. of Associated Spring Corp.
95875.....	Hallet Mfg. Co.

**D-7. Reporting of Equipment Publication Improvements**

DA Form 2028 (Recommended Changes to DA Publications) will be used for reporting discrepancies and recommendations for improving this equipment publication. This form will be completed by the individual using the manual and forwarded direct to Commanding General, U. S. Army Mobility Equipment Command, ATTN: AMSME-MPD, 4300 Goodfellow Blvd., St. Louis, Mo. 63120.

**Section II. PRESCRIBED LOAD ALLOWANCE**

(1) FEDERAL STOCK NUMBER	(2) DESCRIPTION	(3) 15-DAY ORGANIZATIONAL MAINTENANCE ALLOWANCE			
		(a) 1-5	(b) 6-20	(c) 21-50	(d) 51-100
2805-978-7298	0107-ENGINE STARTING SYSTEM SHIELD, SPRING OUTER (29201) 59639A	*	*	2	2
2805-978-7300	SHIELD, SPRING, INNER (29201) 59638A	*	*	2	2
2990-977-1004	GRIP, STARTER ROPE (29201) 58916	*	*	2	2
2990-978-7302	STARTER ROPE (29201) 58806	*	2	2	4
2990-989-3329	FINGER, STARTER (29201) 58756-1	*	*	2	8
5307-978-7078	STUD, SHOULDERED (29201) 568757A1	*	*	2	2
5340-937-5368	SPRING, HELICAL, TORSION (29201) 58758	*	*	2	2
5340-985-2264	SPRING, SPIRAL, TORSION (29201) 58764	*	*	2	2
2805-979-6430	0108-MANIFOLDS MANIFOLD, EXHAUST (29201) 5446-1	*	*	2	2

(1) FEDERAL STOCK NUMBER	(2) DESCRIPTION	(3) 15-DAY ORGANIZATIONAL MAINTENANCE ALLOWANCE			
		(a) 1-5	(b) 6-20	(c) 21-50	(d) 51-100
2940-982-9397	0304-AIR CLEANER ELEMENT, AIR CLEANER, INTAKE	2	7	13	15
5330-937-5360	GASKET, MOUNTING NUT	2	7	13	25
2910-979-6384	0306-TANKS, LINES, FITTINGS CAP ASSEMBLY, FUEL	*	2	2	3
4720-977-1029	(29201) A59911 LINE, FUEL	*	2	2	4
4720-977-1032	(29201) 54543 LINE, FUEL	*	2	2	4
4720-277-1078	(29201) 54426 LINE, FUEL	*	2	2	4
4820-977-1030	(29201) 62704 VALVE. PLUG, 3-WAY	*	2	2	3
2910-977-1082	(292-01) 54521 0309-FUEL FILTER PICKUP ASSEMBLY, FUEL	*	*	2	2
2910-977-1083	(78480) 0W497 ELEMENT, FELT, FILTER	*	2	4	8
2990-983-6332	(78480) 011460 0401-MUFFLER AND PIPES MUFFILER, EXHAUST	*	2	2	3
4730-978-7077	(29201) 54427-1 ELBOW, EXHAUST	*	2	2	3
2920-071-4819	(29201) 54506-1 0605-IGNITION COMPONENTS SPARK PLUG	3	13	25	50
2920-979-6475	(11583) XEJ12 POINT SET, BREAKER	2	7	13	25
5910-937-5849	(79675) X14270C CAPACITOR, FIXED	2	7	13	25
	(79675) X16329				

LINE NO.	(1) SOURCE, MAINT AND RECOV CODE			(2)  FEDERAL STOCK NUMBER	(3)  DESCRIPTION	(4) UNIT OF ISSUE	(5) QTY INC IN UNIT PACK	(6) QTY INC IN UNIT	(7) 15 DAY ORG. MAINT. ALW				(8) ILLUS- TRATION							
	(A)	(B)	(C)						(A)	(B)	(C)	(D)	(A)	(B)						
	S	M	R												1-5	6-20	21-50	51-100	FIG NO.	ITEM OR SYM NO.
	MANUFACTURER'S		CODE												PART NUMBER					
0001					SECTION III - REPAIR PARTS FOR ORGANIZATIONAL MAINTENANCE															
0003					GROUP 01 - ENGINE															
0055					0107 - ENGINE STARTING SYSTEM															
0056	X2	0			HOUSING ASSEMBLY	29201 A54495	EA	1												
0057	X2	0			HOUSING SUBASSEMBLY, FAN AND START	29201 A59562-8	EA	1	SEE GRP 0502											
0058	X2	0			SCREW, MACHINE: PULLEY MTG No. 10-32 THD SIZE, 1/2 IN. LG, SPINLOCK	29201 80648-1	EA	1					D-2	18						
0059	X2	0			WASHER, FLAT: PULLEY MTG, No. 10 SCREW SIZE	29201 58673	EA	1					D-2	19						
0060	X2	0			PULLEY AND CUP ASSEMBLY, STARTER	29201 A58804-1	EA	1					D-2	17						
0061	X1				PULLEY, STARTER	29201 58759-2*	EA	1					D-2	17						
0062	X1				CUP, STARTER	29201 58760-1*	EA	1					D-2	16						
0063	P	0	2805-978-7298		SHIELD, SPRING OUTER	29201 59639A	EA	1	*	*	2	2	D-2	16						
0064	P	0	5340-985-2264		SPRING, SPIRAL, TORSION	29201 58674	EA	1	*	*	2	2	D-2	15						
0065	P	0	2805-978-7300		SHIELD, SPRING, INNER	29201 59683A	EA	1	*	*	2	2	D-2	14						
0066	X2	0			INSERT, ROPE RETAINING	29201 58847-1	EA	1					D-2	5						
0067	P	0	2990-977-1004		GRIP, STARTER ROPE	29201 58915	EA	1	*	*	2	2	D-2	6						
0068	P	0	2990-978-7302		STARTER ROPE	29201 58806	EA	1	*	*	2	2	D-2	8						
0069	X1				BUSHING, STARTER	29201 59313-1	EA	1					D-2	7						
0070	P	0	2990-989-3329		FINGER, STARTER	29201 58756-1	EA	2	*	*	2	2	D-2	26						
0071	X2	0			WASHER, FLAT: FINGER MTG	29201 58851	EA	2					D-2	27						
0072	P	0	5340-937-5358		SPRING, HELICAL, TORSION	29201 58758	EA	2	*	*	2	2	D-2	28						
0073	P	0	5307-978-7078		STUD, SHOULDERED	29201 58757A1	EA	2	*	*	2	2	D-2	25						
0074					0108 - MANIFOLDS															
0075	P	0	2805-979-6430		MANIFOLD, EXHAUST	29201 54456-1	EA	1	*	*	2	2	D-1	7						
0076	X2	0			SCREW, MACHINE: MANIFOLD MTG, No. 12-24 THD SIZE, 3/4 IN. LG, SPINLOCK	29201 80867-1	EA	2					D-1	6						
0077					GROUP 03 - FUEL SYSTEM															
0130					0304 - AIR CLEANER															
0131	X2	0			COVER ASSEMBLY, AIR	29201 A54532	EA	1												
0132	X1				COVER, AIR FILTER	29201 58773-2	EA	1					D-4	2						
0133	X1				NUT, MOUNTING, COVER	29201 A58882-1	EA	1					D-4	1						
0134	X1				RING; RTAINING	29201 58319A	EA	1					D-4	4						
0135	P	0	2940-982-9397		ELEMENT, AIR CLEANER, INTAKE	29201 63589	EA	1	2	7	13	25	D-4	3						
0136	P	0	5330-937-5360		GASKE, MOUNTING NUT	29201 58392-1	EA	1	2	7	13	25	D-4	5						
0137	X2	0			BRACKET ASSEMBLY	29201 A58818-1	EA	1					D-4	8						

LINE NO.	(1) SOURCE, MAINT AND RECOV CODE			(2)  FEDERAL STOCK NUMBER	(3)  DESCRIPTION	(4) UNIT OF ISSUE	(5) QTY INC IN UNIT PACK	(6) QTY INC IN UNIT	(7) 15 DAY ORG. MAINT. ALW				(8) ILLUS- TRATION						
	(A)	(B)	(C)						FEDERAL STOCK NUMBER	DESCRIPTION	UNIT OF ISSUE	QTY INC IN UNIT PACK	QTY INC IN UNIT	(A)	(B)	(C)	(D)	(A)	(B)
	S	M	R											1-5	6-20	21- 50	51-100	FIG NO.	ITEM OR SYM NO.
	MANUFACTURER'S		1-5											6-20	21- 50	51-100	FIG NO.	ITEM OR SYM NO.	
CODE	PART NUMBER																		
0138					0306 - TANKS, LINES, FITTINGS														
0141	P	0		2910-979-6384	CAP, ASSEMBLY, FUEL	29201 A59911	EA	1	*	2	2	3							
0142	X1				CAP, FUEL FILLER	29201 59912	EA	1					D-1	30					
0143	X1				GASKET, FUEL CAP	29201 58957	EA	1					D-1	31					
0144	X1				VALVE, RELIEF	29201 56865-1	EA	1					D-1	32					
0146	P	0		4720-977-1029	LINE, FUEL	29201 54543	EA	1	*	2	2	4							
0147	X2	0			SCREW, MACHINE: TANK ASSEMBLY MTG, HEXAGON HEAD, 1/4-20 THD SIZE, 3/4 IN. LG	29201 63407-2	EA	3					D-1	28					
0148	P	0		4820-977-1030	VALVE, PLUG, 3-WAY	29201 54521	EA	1	*	2	2	3	D-5	58					
0149	X2	0			SCREW, MACHINE: VALVE MTG, FILLISTER HEAD, No. 8-32 THD SIZE, 1 IN. LG	29201 80220-1	EA	2					D-5	56					
0150	X2	0			NUT, SELF-LOCKING VALVE NT, No. 8-32 THD SIZE	29201 81131-1	EA	2					D-5	57					
0151	X2	0			BRACKET, 3-WAY VALVE	29201 54503-1	EA	1					D-5	62					
0152	X2	0			SCREW, MACHINE: BRACKET MTG, No. 10-32 THD SIZE, 3/8 IN. LO	29201 80313-1	EA	2					D-5	59					
0153	X2	0			NUT, SELF-LOCKING: BRACKET MTG, No. 10-32 THD SIZE	29201 81109-1	EA	2					D-5	60					
0154	X2	0			WASHER LOCK: BRACKET AND VALVE MTG No. 10 SCREW SIZE	29201 83046-1	EA	4					D-5	61					
0155	P	0		4720-977-1032	LINE, FUEL	29201 54426	EA	1	*	2	2	4	D-5	55					
0156	X2	0			LINE ASSEMBLY, AUXILIARY FUEL	29201 A54510	EA	1					D-5	53					
0157	P	0		4720-977-1078	LINE, FUEL	29201 62704	EA	1	*	2	2	4	D-5	54					
0190					0309 - FUEL FILTER														
0191	P	0		2910-977-1082	PICKUP ASSEMBLY, FUEL	78480 OW497	EA	1	*	*	2	2							
0192	X1				SHAFT, FILTER	78480 011459	EA	1					D-5	52					
0193	P	0		2910-977-1083	ELEMENT, FELT, FLITER	78180 011460	EA	1	*	2	4	8	D-5	51					
0194					0312 THROTTLE OR CHOKE CONTROLS														
0195	X2	0			ROD ASSEMBLY, CHOKE	29201 A58821-1	EA	1											
0196	X1			2910-979-6424	ROD, SUB ASSEMBLY, CHOKE	29201 A58826-1	EA	1					D-4	13					
0197	X1				BUTTON, CHOKE	29201 57289-1	EA	1					D-4	10					
0198	X2	0			PIN, COTTER: ROD MTG, BRASS, 1/32 IN. DIA, 1/2 IN. LG	29201 86324	EA	1					D-4	12					

LINE NO.	(1) SOURCE, MAINT AND RECOV CODE			(2)  FEDERAL STOCK NUMBER	(3)  DESCRIPTION	(4) UNIT OF ISSUE	(5) QTY INC IN UNIT PACK	(6) QTY INC IN UNIT	(7) 15 DAY ORG. MAINT. ALW				(8) ILLUS- TRATION							
	(A)	(B)	(C)						(A)	(B)	(C)	(D)	(A)	(B)						
	S	M	R												1-5	6-20	21-50	51-100	FIG NO.	ITEM OR SYM NO.
	MANUFACTURER'S		CODE												PART NUMBER					
0199					GROUP 04 - EXHAUST SYSTEM															
0200					0401 - MUFFLER AND PIPES															
0201	X2	0			CLAMP, HOSE: ELBOW MTG	EA	1						D-1	2						
0202	P	0		4730-978-7077	ELBOW, EXHAUST	EA	1	*	2	2	3		D-1	3						
0203	P	0		2990-983-6332	MUFFLER, EXHAUST	EA	1	*	2	2	3		D-1	4						
0204	X2	0			NUT, LOCK: MUFFLER MTG	EA	1						D-	5						
0205					GROUP 05 - COOLING SYSTEM															
0206					0502 - COMLING, DEFLECTORS, AIR DUCT, SHROUDS															
0207	X2	0			HOUSING SUBASSEMBLY, FAN AND START	EA							D-2	4						
0213					GROUP 06 - ELECTRICAL SYSTEM															
0214					0605 - IGNITION COMPONENTS															
0219	X2	0			SPRING, BEAKER BOX COVER	EA	1						D-2	32						
0220	X2	0		2920-979-6475	POINT SET, BREAKER	EA	1	2	7	13	25		D-2	45						
0232	P	0		5910-937-5849	CAPACITOR, FIXED	EA	1	2	7	13	25		D-2	44						
0233	X2	0			CLAP, CAPACITOR	EA	1						D-2	44						
0239	X2	0			COVER, BREAKER BOX	EA	1						D-2	30						
0240	X2	0			GASKET, BREAKER BOX COVER	EA	1						D-2	31						
0243	P	0		2920-071-1819	SPARK PLUG	EA	1	2	13	25	50		D-1	1						
0244	X1				GASKET, SPARK PLUG	EA	1													
0252					GROUP 15 - FRAME, TOWING ATTACHMENTS AND DRAWBARS															
0253					1501 FRAME ASSEMBLY															
0254	X2	0			GRIP, HANDLE	EA	1						D-5	37						
0255	X2	0			SCREW, MACHINE: GRIP MTG, FILLISTER HEAD, No. 10-24 THD SIZE, 5/8 IN. LG	EA	2						D-5	35						
0256	X2	0			WASHER, LOCK: GRIP MTG, No. 10 SCREW SIZE	EA	2						D-5	36						
0257	X2	0			BRACKET, HANDLE	EA	1						D-5	40						
0258	X2	0			SCREW, MACHINE: BRACKET MTG, PAN HEAD, No. 8-32. THD SIZE, 1/2 IN. LG	EA	2													
0259	X2	0			SKID AND SPRING ASSEMBLY (COMPONENTS SAME AS SKID AND SPRING ASSEMBLY, STOCK NO. (29201) A54484)	EA	1													

LINE NO.	(1) SOURCE, MAINT AND RECOV CODE			(2)  FEDERAL STOCK NUMBER	(3)  DESCRIPTION	(4) UNIT OF ISSUE	(5) QTY INC IN UNIT PACK	(6) QTY INC IN UNIT	(7) 15 DAY ORG. MAINT. ALW				(8) ILLUS- TRATION							
	(A)	(B)	(C)						(A)	(B)	(C)	(D)	(A)	(B)						
	S	M	R												1-5	6-20	21-50	51-100	FIG NO.	ITEM OR SYM NO.
	MANUFACTURER'S		CODE												PART NUMBER					
0260	X2	0			SKID AND SPRING ASSEMBLY	EA		1												
0261	X2	0			SPRING, SPIRAL	EA		4					D-5	69						
0262	X2	0			SCREW, MACHINE: SPRING MTG, No. 10-32 THD SIZE, 3/8	EA		4					D-5	63						
0263	X2	0			WASHER, FLAT: SPRING MTG	EA		4					D-5	65						
0264	X2	0			NUT, SELF-LOCKING, HEXAGON: SPRING MTG, No. 10-32 THD SIZE	EA		4					D-5	68						
0265	X2	0			SKID	EA		2					D-5	70						
0266	X2	0			SCREW, MACHINE: SKID ASSEMBLY NTO, No. 10-32 THD SIZE, 9/16 IN. LG, SPINLOCK	EA		4					D-5	67						
0267	X2	0			WASHER, LOCK: SKID ASSEMBLY MTG No. 10 CREW SIZE	EA		4					D-5	64						
0268	X2	0			WASHER, FLAT: SKID ASSEMBLY MTG, No. 10 SCREW SIZE	EA		8					D-5	66						
0269					GROUP 18 - BODY, CAB, HOOD AND HULL															
0270					8308 - STOWAGE RACKS, BOXES, CARRYING CASES															
0271	X2	0			CASE ASSEMBLY, CARRYING	EA		1												
0272	X2	0			BAG, SPARE PARTS	EA		1												
0273					GROUP 22 - BODY, CHASSIS OR HULL AND ACCESSORY ITEMS															
0274					2210 - DATA PLATES															
0278	X2	0			SCREW, DRIVE: PLATE MTG	EA		4												
0279	X2	0			PLATE, INSTRUCTION: STARTING	EA		1												

LINE NO.	(1) SOURCE, MAINT AND RECOV CODE			(2)  FEDERAL STOCK NUMBER	(3)  DESCRIPTION	(4) UNIT OF ISSUE	(5) QTY INC IN UNIT PACK	(6) QTY INC IN UNIT	(7) 30-DAY DS/GS MAINT. ALW.			(8)  1 YR ALW PER 100 EQUIP  CTYGCY  PLANN- ING	(9)  DEPOT MAINT ALW PER 100 EQUIP	(10) ILLUS- TRATION		
	(A)	(B)	(C)						1-20	21-50	51-100			(A)	(B)	
	S	M	R													
	MANUFACTURER'S															
CODE	PART NUMBER															
0002					SECTION IV - REPAIR PARTS FOR DS, GS, AND DEPOT MAINTENANCE											
0003					GROUP 01 - ENGINE											
0004					0100 - ENGINE ASSEMBLY											
0005	P	F	T	2805-087-1508	ENGINE, GASOLINE (HOMELITE MODEL)	29201 A54770	EA	1	2	2	3	30	5			
0006					0101 - CRANKCASE, BLOCK, CYLINDER HEAD											
0007	X1				CRANKCASE ASSEMBLY	29201 A8799-2	EA	1								
0008	X1				CRANKCASE	29201 58410-3	EA	1							D-1	29
0009	P	F		5330-852-5034	SEAL, PLAIN ENCASED	29201 58688A	K	2	2	4	8	100	100		D-1	22
0010	P	F		3110-117-1347	BEARING, ROLLER	60380 BH108	EA	2	4	8	15	180	100		D-1	23
0011	P	F		2805-983-6329	GASKET: CYLINDER	29201 58513	PK	10	1	2	3	5	60	10	0-1	11
0012	P	F		2805-983-6330	CYLINDER	29201 5870682	EA	1	2	2	3	30	5		D-1	10
0013	X1			5307-997-6090	STUD, PLAIN: CYLINDER MTG	29201 56470-1	EA	4							D-1	12
0014	X2	F			WASHER, LOCK CYLINDER MTG, 1/4 IN SCREW, SIZE	29201 83099-1	EA	4							D-1	9
0015	X2	F			NUT PLAIN, HEXAGON: CYLINDER MTG, 1/4-28 THD SIZE	29201 81065-4	EA	4							D-1	8
0016	X1				DRIVECASE ASSEMBLY	29201 A54494	EA	1								
0011	P	F		5330-852-5034	SEAL, PLAIN ENCASED	29201 58688A	PK	2	1	2	4	8	100	100	D-5	31
0018	P	F		5325-270-8886	GROMMET, RUBBER	70485 2752	EA	1	2	3	5	60	100		D-5	12
0019	P	F		3110-117-1347	BEARING, ROLLER	60380 BH108	EA	1	4	8	15	180	100		D-5	33
0020	X1				DRIVECASE	29201 59437-2	EA	1							D-5	71
0021	P	F		2805-981-8749	GASKET, CRANKCASE	29201 63355	PK	10	1	2	3	5	60	10	D-5	34
0022	X2	F			SCREW, MACHINE: DRIVECASE MTG, No. 12-24 THD SIZE, 9/16 IN. LG, SPINLOCK	29201 80899-1	EA	5							D-5	32
0023					0102 - CRANKSHAFT											
0024	X2	F			CRANKSHAFT ASSEMBLY	29201 A64198	EA	1								
0025	P	F		2805-978-7291	CRANKSHAFT	29201 63497	EA	1	2	2	3	30	10		D-1	27
0026	P	F		5315-018-9576	KEY, VOOORFF	29201 75078	EA	1	2	2	3	30	10		D-1	21
0027	P	F		5310-986-3587	WASHER, SPRING	92830 S10A	EA	1	2	2	3	30	30		D-1	24
0028	P	F		3110-926-4584	RACE, BEARING	60380 TRA1018	EA	2	3	5	10	120	100		D-1	25
0029	P	F		3110-629-4112	BEARING, ROLLER	60380 NTA1018	EA	2	3	5	10	120	100		D-1	26
0030					0103 - FLYWHEEL ASSEMBLY											
0031	X2	F			ROTOR AND STARTER FINGER ASSEMBLY	29201 A58808-1	EA	1								
0032	X1				ROTOR, MAGNETO	79575 Y14180B	EA	1							D-2	29

LINE NO.	(1) SOURCE, MAINT AND RECOV CODE			(2)  FEDERAL STOCK NUMBER	(3)  DESCRIPTION	(4) UNIT OF ISSUE	(5) QTY INC IN UNIT PACK	(6) QTY INC IN UNIT	(7) 30-DAY DS/GS MAINT. ALW.			(8)  1 YR ALW PER 100 EQUIP  CTYGCY  PLANN- ING	(9)  DEPOT MAINT ALW PER 100 EQUIP	(10) ILLUS- TRATION	
	(A)	(B)	(C)						1-20	21-50	51-100			(A)	(B)
	S	M	R												
	MANUFACTURER'S		FIG NO.												
CODE	PART NUMBER														
0033	X2	F		SCREEN: ROTOR	29201 58765-1	EA		1	SEE	GRP 0502					
0034	X2	F		NUT, PLAIN, HEXAGON: ROTOR MTG	29201 81117-1	EA		1						D-2	22
0035	X2	F		WASHER, FLAT, ROTOR MTG	29201 84056-1	EA		1						D-2	24
0036	X2	F		WASHER, LOCK: ROTOR MTG	29201 83002-1	EA		1						D-2	23
0037				0104 - PISTONS, CONNECTING RODS											
0038	X1			PISTON AND ROD ASSEMBLY	29201 A64043	EA		1							
0039	X1			PISTON, INTERNAL COMBUSTION ENGINE	29201 63888	EA		1						D-1	20
0040	X1			PIN, SPRING	29201 63962	EA		1							
0041	X1			PIN, SPRING	29201 63963	EA		1							
0042	P	F	2805-597-7293	ROD ASSEMBLY, CONNECTING	29201 A63477	EA		1	2	2	3	30	25	D-1	15
0043	X1			ROD SUBASSEMBLY, CONNECTING	29201 A63478	EA		1							
0044	X2	F		SCREW, MACHINE: ROD	29201 80889	EA		2						D-1	13
0045	P	F	3110-198-1061	BEARING, ROLLER	60380 B68	EA		1	2	2	3	30	25	D-1	16
0046	P	F	2805-984-5008	RING SET, PISTON	29201 A54565	EA		1	4	8	15	100	100		
0047	X1			RING, PISTON	53781 XHBD89	EA		2						D-1	19
0048	P	F	3110-937-5737	ROLLER SET: ROD ASSEMBLY	29201 A63496	EA		1	2	2	3	30	100	D-1	14
0049	X1			ROLLER, BEARING	60380 QE32413	EA		1							
0050	P	F	2805-978-7294	PISTON AND PIN	29201 A64056	EA		1	2	2	3	30	100		
0051	X1			PISTON AND PIN	29201 A64045	EA		1							
0052	X1			PIN, PISTON	29201 63600	EA		1						D-1	18
0053	X2	F	5340-805-0340	RING, RETAINING: PISTON PIN	79136 N5000-37	EA		1						D-1	17
0054	X1			PISTON AND SPIRAL PIN ASSEMBLY	29201 A63964										
0055				0107 - ENGINE STARTING SYSTEM											
0056	X2	0		HOUSING ASSEMBLY	29201 A54495	EA		1							
0057	X2	0		HOUSING SUBASSEMBLY, FAN AND START	29201 A59562-8	EA		1	SEE	GRP 0502					
0058	X2	0		SCREW, MACHINE: PULLEY MTG No. 10-32 THD SIZE, 1/2 IN. LG, SPINLOCK	29201 80648-1	EA		1						D-2	18
0059	X2	0		WASHER, FLAT: PULLEY MTG, No. 10 SCREW SIZE	29201 58763	EA		1						D-2	19
0060	X2	0		PULLEY AND CUP ASSEMBLY, STARTER	29201 A58804-1	EA		1							
0061	X1			PULLEY, STARTER	29201 58759-2	EA		1						D-2	17
0062	X1			CUP, STARTER	29201 58760-1	EA		1							
0063	P	0	2805-978-7298	SHIELD, SPRING OUTER	29201 59639A	EA		1	2	2	3	30	5	D-2	16
0064	P	0	5340-985-2264	SPRING, SPIRAL, TORSION	29201 58764	EA		1	2	2	3	30	5	D-2	15
0065	P	0	2805-978-7300	SHIELD, SPRING, INNER	29201 59638A	EA		1	2	2	3	30	5	D-2	14
	X2	0		INSERT, ROPE RETAINING	29201 58847-1	EA		1						D-2	5
0067	P	0	2990-977-1004	GRIP, STARTER ROPE	29201 58915	EA		1	2	2	3	30	5	D-2	6
0068	P	0	2990-978-7302	STARTER ROPE	29201 58806	EA		1	2	4	8	100	100	D-2	8
0069	X1			BUSHING, STARTER	29201 59313-1	EA		1						D-2	7
0070	P	0	2990-989-3329	FINGER, STARTER	29201 58756-1	EA		2	2	2	3	30	20	D-2	26
0071	X2	0		WASHER, FLAT: FINGER MTG	29201 58851	EA		2						D-2	27
0072	P	0	5310-937-5358	SPRING, HELICAL, TORSION	29201 58758	EA		2	2	2	3	30	30	D-2	28
0073	P	0	5307-978-7078	STUD, SHOULDERED	29201 58757A1	EA		2	2	2	3	30	10	D-2	25



LINE NO.	(1) SOURCE, MAINT AND RECOV CODE			(2)  FEDERAL STOCK NUMBER	(3)  DESCRIPTION	(4) UNIT OF ISSUE	(5) QTY INC IN UNIT PACK	(6) QTY INC IN UNIT	(7) 30-DAY DS/GS MAINT. ALW.			(8)  1 YR ALW PER 100 EQUIP  CTYGCY  PLANN- ING	(9)  DEPOT MAINT ALW PER 100 EQUIP	(10) ILLUS- TRATION	
	(A)	(B)	(C)						1-20	21-50	51-100			(A)	(B)
	S	M	R												
	MANUFACTURER'S		FIG NO.												
CODE	PART NUMBER														
0074				2805-979-6430	0108 - MANIFOLDS MANIFOLD, EXHAUST	EA		1	2	2	3	30	10	D-1	7
0075	P	0			SCREW, MACHINE: MANIFOLD MTG, No. 12-24	EA									
0076	X2	0			THD SIZE, 3/4 IN. LG, SPINLOCK GROUP 03 - FUEL SYSTEM	EA		2						D-1	16
0077															
0078				2910-981-5009	0301 - CARBURETOR CARBURETOR	EA		1	2	2	3	30	20	D-4	19
0079	P	F			CARBURETOR SUBASSEMBLY	EA		1							
0080	X1				COVER, PUMP	EA		1						D-3	3
0081	X1				SCREW, MACHINE: COVER MTG FILLISTER HEAD, No. 6-32 THD SIZE, 3/8 IN. LG	EA		4						D-3	1
0082	X1				WASHER LOCK: COVER MTG, No. 6 SCREW SIZE	EA		4						D-3	2
0083	X1				GASKET, FUEL PUMP: COVER	EA		1						D-3	4
0084	X1				DIAPHRAGM, FUEL	EA		1						D-3	5
0085	X1				SCREEN	EA		1						D-3	6
0086	X1				COVER, DIAPHRAGM	EA		1						D-3	9
0087	X1				SCREW, MACHINE: DIAPHRAGM COVER MTG, ROUND HEAD, No. 4-40 THD SIZE, 1/4 IN. LG	EA		4						D-3	7
0088	X1				WASHER LOCK: DIAPHRAGM COVER MTG, No. 4 SCREW SIZE	EA		4						D-3	8
0089	X1				DIAPHRAGM	EA		1						D-3	10
0090	X1				GASKET, DIAPHRAGM	EA		1						D-3	11
0091	X1				SCREW, TAPPING, THREAD CUTTING	EA		1						D-3	12
0092	X1				PIN, FULCRUM: INLET LEVER	EA		1						D-3	13
0093	X1				LEVER, INLET	EA		1						D-3	11
0094	X1				SPRING, HELICAL, COMPRESSION	EA		1						D-3	15
0095	X1				NEEDLE, INLET	EA		1						D-3	17
0096	X1				PLUG, EXPANSION	EA		1						D-3	16
0097	X1				SCREW, MAIN ADJUSTNENT	EA		1						D-3	18
0098	X1				SPRING, HELICAL, COMPRESSION	EA		1						D-3	19
0099	X1				SHUTTER, CHOKE	EA		1						D-3	21
0100	X1				SHAFT AND LEVER	EA		1						D-3	20
0101	X1				BALL, BEARING	EA		1						D-3	22
0102	X1				SPRING, HELICAL, COMPRESSION	EA		1						D-3	23
0103	X1				PIN, SPRING	EA		1						D-3	28
0104	X1				SHUTTER, THROTTLE	EA		1						D-3	27
0105	X1				SCREW, MACHINE: SHUTTER MTG, No. SCREW SIZE	EA		1						D-3	24
0106	X1				WASHER, LOCK: SHUTTER AND CLIP NTG	EA		2						D-3	25
0107	X1														

LINE NO.	(1) SOURCE, MAINT AND RECOV CODE			(2)  FEDERAL STOCK NUMBER	(3)  DESCRIPTION	(4) UNIT OF ISSUE	(5) QTY INC IN UNIT PACK	(6) QTY INC IN UNIT	(7) 30-DAY DS/GS MAINT. ALW.			(8)  1 YR ALW PER 100 EQUIP  CTYGCY  PLANN- ING	(9)  DEPOT MAINT ALW PER 100 EQUIP	(10) ILLUS- TRATION	
	(A)	(B)	(C)						1-20	21-50	51-100			(A)	(B)
	S	M	R												
	MANUFACTURER'S		FIG NO.												
CODE		PART NUMBER													
0108	X1				CLIP, THROTTLE	EA		1						D-3	26
0109	X1				SCREW, MACHINE: CLIP MTG ROUND HEAD, No. 4-40 THD SIZE, 3/16 IN. LG	EA		1							
0110	X1				SHAFT AND LEVER, THROTTLE	EA		1						D-3	29
0111	X1				BODY	EA		1						D-3	30
0112	X1		2910-984-5010		KIT, REPAIR, CARBURETOR	EA		1							
0113	X2	F			CHAMBER ASSEMBLY, CARBURETOR	EA		1						D-4	24
0114	P	F	2910-997-1006		CHAMBER SUBASSEMBLY, CARBURETOR	EA		1	*	*	*	5	3		
0115	X2	F			GROMMET AND PLUG ASSEMBLY	EA		1							
0116	X2	F			GROMMET, RUBBER	EA		1						D-4	17
0117	X2	F			PLUG, RUBBER	EA		1						D-4	18
0118	X2	F			GROMMET, RUBBER	EA		1						D-4	11
0119	X2	F			PLUG, FELT	EA		1						D-4	9
0120	X2	F			STOP, REED	EA		1						D-4	26
0121	X2	F			SPRING, REED	EA		1						D-4	27
0122	X2	F			REED	EA		1						D-4	28
0123	X2	F			SCREW, MACHINE: REED MTG	EA		2						D-4	25
0124	X2	F			PIN, COTTER	EA		1						D-4	22
0125	X2	F			SCREW, MACHINE: CHAMBER ASSEMBLY MTG, HEXAGON HEAD, No. 12-24 THD SIZE, 7/8 IN. LG	EA		5						D-4	23
0126	X2	F			SCREW, MACHINE: CARBURETOR MTG, HEXAGON HEAD, NO. 10-32 THD SIZE, 2 1/4 IN. LG	EA		2						D-4	6
0127	X2	F			WASHER, LOCK: CARBURETOR MTG, No. 10 SCREW SIZE	EA		2						D-4	7
0128	P	F	2910-977-1005		GASKET: CARBURETOR MTG	PK	2	2	2	3	5	60	100	D-4	20
0129	P	F	2805-978-7306		DAMPER, HEAT	EA		1	2	2	3	30	100	D-4	21
0130					0304 - AIR CLEANER										
0131	X2	0			COVER ASSEMBLY, AIR	EA		1							
0132	X1				COVER, AIR FILTER	EA		1						D-4	2
0133	X1				NUT, MOUNTING, COVER	EA		1						D-4	1
0134	X1				RING, RETAINING	EA		1						D-4	4
0135	P	0	2940-982-9397		ELEMENT, AIR CLEANER, INTAKE	EA		1	13	25	50	600	100	D-4	3
0136	P	0	5330-937-5360		GASKET, MOUNTING NUT	EA		1	13	25	50	600	100	D-4	5
0137	X2	0			BRACKET ASSEMBLY	EA		1						D-4	8
0138					0306 - TANKS, LINES, FITTINGS										
0139	X1				TANK ASSEMBLY, FUEL	EA		1						D-1	34
0140	P	F	2910-977-1028		TANK SUBASSEMBLY, FUEL	EA		1	*	*	*	5	5		
0141	P	0	2910-979-6385		CAP, ASSEMBLY, FUEL	EA		1	2	3	5	60	10		
0142	X1				CAP, FUEL FILLER	EA		1						D-1	30
0143	X1				GASKET, FUEL CAP	EA		1						D-1	31

LINE NO.	(1) SOURCE, MAINT AND RECOV CODE			(2)  FEDERAL STOCK NUMBER	(3)  DESCRIPTION	(4) UNIT OF ISSUE	(5) QTY INC IN UNIT PACK	(6) QTY INC IN UNIT	(7) 30-DAY DS/GS MAINT. ALW.			(8) 1 YR ALW PER 100 EQUIP  CTYGCY  PLANN- ING	(9) DEPOT MAINT ALW PER 100 EQUIP	(10) ILLUS- TRATION	
	(A)	(B)	(C)						1-20	21-50	(C) 51-100			(A)	(B)
	S	M	R												
	MANUFACTURER'S		FIG NO.												
CODE		PART NUMBER													
0144	X1				VALVE, RELIEF	EA		1						D-1	32
0145	X1		4730-978-7076		ELBOW, PIPE TO TUBE: LINE TO TANK	EA		1						D-1	33
0146	P	0	4720-977-1029		LINE, FUEL	EA		1	2	4	8	100	100		
0147	X2	0			SCREW, MACHINE: TANK ASS'NBLY MTG, HEXAGON HEAD, 1/4-20 THD SIZE, 3/4 IN. LG	EA		1							
					29201 63407-2	EA		3						D-1	28
0148	P	0	4820-977-1030		VALVE, PLUG, 3-WAY	EA		1	2	3	5	60	10	D-5	58
0149	X2	0			SCREW, MACHINE: VALVE MTG, FILLISTER HEAD, No. 8-32 TNO SIZE , 1 IN. LG	EA		2						D-5	56
					29201 80220-1	EA		2						D-5	56
0150	X2	0			NUT, SELF-LOCKING: VALVE MTG No. 8-32 THD SIZE	EA		2						D-5	57
					29201 81131-1	EA		1						D-5	62
0151	X2	0			BRACKET, 3-WAY VALVE	EA		1						D-5	62
0152	X2	0			SCREW, MACHINE: BRACKET MTG, No. 10-32 THD SIZE, 3/8 IN. LG	EA		2						D-5	59
					29201 80313-1	EA		2						D-5	59
0153	X2	0			NUT, SELF-LOCKING: BRACKET MTG, No. 10-32 THD SIZE	EA		2						D-5	60
					29201 81109-1	EA		2						D-5	60
0154	X2	0			WASHER, LOCK: BRACKET AND VALVE MTG, No. 10 SCREW SIZE	EA		4						D-5	61
					29201 83046-1	EA		1	2	4	8	100	100	D-5	55
0155	P	0	4720-977-1032		LINE, FUEL	EA		1						D-5	55
0156	X2	0			LINE ASSEMBLY, AUXILIARY FUEL	EA		1						D-5	53
0157	P	0	4720-977-1078		LINE, FUEL	EA		1	2	4	8	100	100	D-5	54
0158					0308 - ENGINE SPEED GOVERNOR AND CONTROLS	EA		1						D-5	54
					29201 62704	EA		1	2	4	8	100	100	D-5	54
0159	X2	F			GOVERNOR AND SHAFT ASSEMBLY	EA		1						D-5	21
					29201 A54485	EA		1	2	2	3	30	10	D-5	26
0160	P	F	2990-984-5011		BACK PLATE ASSEMBLY	EA		1						D-5	25
0161	X1				BACKPLATE, GOVERNOR	EA		1						D-5	24
0162	X1				ARM, GOVERNOR	EA		2						D-5	23
0163	X1				WEIGHT, GOVERNOR	EA		2						D-5	22
0164	X1				SCREW, MACHINE: WEIGHT MTG, No. 6-32 THD SIZE, 5/16 IN. LG	EA		4						D-5	27
					29201 80605-1	EA		2						D-5	27
0165	X1				PIN, PIVOT	EA		2						D-5	28
					29201 59747-1	EA		4						D-5	22
0166	X1				PIN, COTTER: PIVOT PIN	EA		4						D-5	22
0167	P	F	2990-984-5012		CUP, GOVERNOR	EA		1	2	3	5	60	10	D-5	27
					29201 59522	EA		1	2	2	3	30	10	D-5	28
0160	P	F	2990-983-6331		SPRING, GOVERNOR	EA		1						D-5	28
					29201 59574	EA		1						D-5	28
0169	X2	F			SCREW, MACHINE	EA		1						D-5	47
					29201 80919-1	EA		1						D-5	41
0170	X2	F			WASHER, FLAT	EA		1						D-5	42
					29201 84011-1	EA		1						D-5	42
0171	X1				GUIDE, GOVERNOR SHAFT	EA		1						D-5	47
					29201 59692	EA		1						D-5	41
0172	X2	F			SCREW, MACHINE: GUIDE MTG	EA		2						D-5	41
					29201 80560-1	EA		2						D-5	42
0173	X2	F			WASHER, FLAT: GUIDE MTG	EA		2						D-5	42
					29201 64139	EA		2						D-5	42
0174	P	F	5310-986-3545		WASHER, CENTERING	EA		1	2	2	3	30	10	D-5	29
					29201 59577-1	EA		1	2	2	3	30	10	D-5	29
0175	P	F	5340-987-5599		RING, RETAINING	EA		1	2	3	5	60	10	D-5	30
					29201 71119-1	EA		1	2	3	5	60	10	D-5	30
0176	P	F	2990-977-1084		GOVERNOR AND CAM ASSEMBLY	EA		1	2	3	5	60	10	D-5	30
					29201 A59893-1	EA		1	2	3	5	60	10	D-5	30
0177	X1				CAM AND SHAFT	EA		1						D-5	46
					29201 M54039	EA		1						D-5	46

LINE NO.	(1) SOURCE, MAINT AND RECOV CODE			(2)  FEDERAL STOCK NUMBER	(3)  DESCRIPTION	(4) UNIT OF ISSUE	(5) QTY INC IN UNIT PACK	(6) QTY INC IN UNIT	(7) 30-DAY DS/GS MAINT. ALW.			(8)  1 YR ALW PER 100 EQUIP  CTYGCY  PLANN- ING	(9)  DEPOT MAINT ALW PER 100 EQUIP	(10) ILLUS- TRATION	
	(A)	(B)	(C)						1-20	21-50	51-100			(A)	(B)
	S	M	R												
	MANUFACTURER'S		CODE												
0178	X2	F			CONNECTOR, CABURETOR LINK	29201 59758	EA		1						
0119	X2	F		LINK, CARBURETOR	29201 5974-1	EA		1						D-5	48
0180	X2	F		CONNECTOR, CARBURETOR	29201 59758	EA		1						D-5	45
0181	X2	F		SCREW, MACHINE: CONNECTOR MTG, ROUND HEAD, No. 4-40 THD SIZE, 3/4 IN. LG	29201 80628-1	EA		1						D-5	43
0182	X2	F		WASHER, LOCK: CONNECTOR MTG, No. 4 SCREW SIZE	29201 83073-1	EA		1						D-5	49
0183	X2			WASHER, FLAT CONNICTON MTG, No. 4 SCREW SIZE	29201 84011-1	EA		1						D-5	44
0184	P	F	2911-979-6416	EXTENSION, THROTTLE SHAFT	29201 59759	EA		1	2	2	3	30	10	D-5	50
0185	X2	F		GUARD, GOVERNOR LINKAGE	29201 54490-1	EA		1						D-5	3
0186	P	F	2910-977-1098	PLATE ASSEMBLY, SPEED ADJUSTING	29201 A59299-1	EA		1	2	2	3	30	10	D-4	16
0187	X2	F		SCREW, MACHINE: PLATE MTG, PAN HEAD, No.8-32 THD SIZE, 1/4 IN. LG	29201 80575-1	EA		2						D-4	15
0188	P	F	5340-839-5600	SPRING, HELICAL, EXTENSION	29201 59242	EA		1	2	3	5	60	20	D-4	14
0189	X2	F		SCREW, MACHINE: GUARD MTG	29201 80560-1	EA		2						D-5	38
0190				0309 - FUEL FILTER											
0191	P	0	2910-977-1082	PICKUP ASSEMBLY, FUEL	78480 0W497	EA		1	2	2	3	30	5		
0192	X1			SHAFT, FILTER	78480 011459	EA		1						D-5	52
0193	P	0	2910-977-1083	ELEMENT, FELT, FILTER	78480 011460	EA		1	4	8	15	180	100	D-5	51
0191				0312 - THROTTLE OR CHOKE CONTROLS											
0195	X2	0		ROD ASSEMBLY, CHOKE	29201 A58821-1	EA		1							
0196	X1		2910-979-6424	ROD, SUBASSEMBLY, CHOKE	29201 A5826-1	EA		1						D-4	13
0197	X1			BUTTON, CHOKE	29201 57289-1	EA		1						D-4	10
0198	X2	0		PIN, COTTER: ROD MTG, BRASS, 1/32 IN. DIA, 1/2 IN. LG	29201 86324	EA		1						D-4	12
0199				GROUP 04 - EXHAIST SYSTEM											
0200				0401 - MUFFLER AND PIPES											
0201	X2	0		CLAMP, HOSE: ELBOW MTG	29201 54507-1	EA		1						D-1	2
0202	P	0	4730-978-7077	ELBOW, EXHAUST	29201 54506-1	EA		1	2	3	5	60	10	D-1	3
0203	P	0	2990-983-6332	MUFFLER, EXHAUST	29201 54427-1	EA		1	2	3	5	60	10	D-1	4
0204	X2	0		NUT, LOCK: MUFFLER MTG	29201 59510-1	EA		1						D-1	5

LINE NO.	(1) SOURCE, MAINT AND RECOV CODE			(2)  FEDERAL STOCK NUMBER	(3)  DESCRIPTION	(4) UNIT OF ISSUE	(5) QTY INC IN UNIT PACK	(6) QTY INC IN UNIT	(7) 30-DAY DS/GS MAINT. ALW.			(8) 1 YR ALW PER 100 EQUIP  CTYGCY  PLANN- ING	(9) DEPOT MAINT ALW PER 100 EQUIP	(10) ILLUS- TRATION		
	(A)	(B)	(C)						1-20	21-50	(C)			(A)	(B)	
	S	M	R													
	MANUFACTURER'S		FIG NO.													ITEM OR SYM NO.
CODE	PART NUMBER															
0205					GROUP 05 - COOLING SYSTEM											
0206					0502 COWLING, DEFLECTORS, AIR DUCT, SHROUDS											
0207	X2	0			HOUSING SUBASSEMBLY, FAN AND START	29201	A59562-8	EA	1						D-2	4
0208	X2	F			NUT, SELF-LOCKING, HEXAGON: SCREEN MTG, No. 10-32 THD SIZE	29201	81109-1	EA	2						D-2	20
0209	X2	F			SCREEN: ROTOR	29201	58765-1	EA	1						D-2	21
0210	X2	F			SCREW, MACHINE: HOUSING MTG, No. 12-24 THD SIZE 1 5/8 IN. LG, SPINLOCK	29201	80676-1	EA	1						D-2	1
0211	X2	F			SCREW, MACHINE: HOUSING MTG, No. 12-24 THD SIZE, 1 11/16 IN. LG, SPINLOCK	29201	58963-1	EA	3						D-2	2
0212	X2	F			WASHER, LOCK: HOUSING MTG, INTERNAL TEETH No. 10 SCREW SIZE	29201	83075-1	EA	4						D-2	3
0213					GROUP 06 - ELECTRICAL SYSTEM											
0214					0605 - IGNITION COMPONENTS											
0215	X2	F		2920-977-1118	GROUP ANO LEAD ASSEMBLY, STATOR PLATE	29201	A54409	EA	1							
0216	P	F			LEAD, HIGH TENSION	95875	10377	EA	1	2	2	3	30	5	D-2	42
0217	X2	F			SCREW, MACNINE: STATON PLATI NTG	29201	6761	EA	3						D-2	50
0218	X2	F			GROUP ASSEMBLY, STATOR PLATE	29201	A5410	EA	1						D-2	
0219	X2	0			SPRING, BREAKER BOX COVER	29201	76413	EA	1						D-2	32
0220	P	0		2920-979-6475	POINT SET, BREAKER	79575	X14270C	EA	1	13	25	50	600	100	D-2	
0221	X2	F			CONNECTION UNIT	79575	X14277	EA	1						D-2	36
0222	X2	F			NUT, PLAIN, HEXAGON CONNECTION UNIT MTG	79507	11015	EA	1						D-2	34
0223	X1				WASHER, LOCK: CONNECTION UNIT MTG	79575	M90X	EA	1						D-2	35
0224	X1				INSULATOR, CONNECTOR	79575	13309	EA	1							
0225	X1				STUD, CONNECTING	79575	14175	EA	1						D-2	37
0226	X1				SCREW, ASSEMBLED WASHER: POINT SET MTG	29201	76421	EA	2						D-2	33
0227	X1				FELT, CAM WIPER	79575	14956	EA	1						D-2	46
0228	X1				CLIP, HAIRPIN	79575	4210	EA	1						D-2	38
0229	X1				SHIM	79575	10407	EA	2						D-2	39
0230	X1				ARM GROUP, BREAKER	79575	X14173	EA	1						D-2	40
0231	X1				CONTACT, FIXED	79575	X14166	EA	1						D-2	41
0232	P	0		5910-937-5849	CAPACITOR, FIXED	79575	X16329	EA	1	13	25	50	600		D-2	45
0233	X2	0			CLAMP, CAPACITOR	79575	14954	EA	1						D-2	44
0234	X1				SCREW, CAPTIVE	29201	30261	EA	1						D-2	43
0235	X1				WEDGE, COIL	29201	63726	EA	1						D-2	48
0236	X2	F			SCREW, COIL ROUND	29201	58872	EA	1						D-2	47
0237	X1				COIL, IGNITION	79575	X1417C	EA	1						D-2	49

LINE NO.	(1) SOURCE, MAINT AND RECOV CODE			(2)  FEDERAL STOCK NUMBER	(3)  DESCRIPTION	(4) UNIT OF ISSUE	(5) QTY INC IN UNIT PACK	(6) QTY INC IN UNIT	(7) 30-DAY DS/GS MAINT. ALW.			(8)  1 YR ALW PER 100 EQUIP  CTYGCY  PLANN- ING	(9)  DEPOT MAINT ALW PER 100 EQUIP	(10) ILLUS- TRATION	
	(A)	(B)	(C)						1-20	21-50	51-100			(A)	(B)
	S	M	R												
	MANUFACTURER'S														
CODE	PART NUMBER														
0238	X1				PLATE, STATOR	EA		1						D-2	51
0239	X2	0			COVER, BREAKER SOX	EA		1						D-2	30
0240	X2	0			GASKET, BREAKER BOX COVER	EA		1						D2	31
0241	X1				SEAL, FELT	EA		1						D2	52
0242	P	F		5330-852-5030	GASKET	EA		1	2	3	5	60	100	D2	53
0243	P	0		2920-071-4819	SPARK PLUG	EA		1	25	50	100	1200	100	D-1	1
0244	X1				GASKET, SPARK PLUG	EA		1							
0245	X2	F			LEAD ASSEMBLY, WND	EA		1						D-2	11
0246	X1				TERMINAL, QUICK DISCONNECT	EA		1						D-2	9
0247	X1				TERMINAL, QUICK DISCONNECT	EA		1						D2	10
0248	X2	F			LEAD, ELECTRICAL	EA		1							
0249					0607 - INSTRUMENT OR ENGINE CONTROL PANEL										
0250	P	F		5930-988-7260	SWITCH, TOGGLE	EA		1	2	2	3	30	5	D-2	13
0251	X1				NUT, PLAIN, NEXAGON: SVITCH MTG	EA		1						D-2	12
0252					GROUP 15 - FRAME, TOWING ATTACHMENTS AND DRAWBARS										
0253					1501 - FRAME ASSEMBLY										
0254	X2	0			GRIP, HANDLE	EA		1						D-5	37
0255	X2	0			SCREW, MACHINE: GRIP MTG FILLISTER HEAD, No. 10-24 THD SIZE, 5/8, 1N. LG	EA		2						D-5	35
0256	X2	0			WASHER, LOCK: GRIP MTG, No. 10 SCREW SIZE	EA		2						D-5	36
0257	X2	0			BRACKET, HANDLE	EA		1						D-5	40
0258	X2	0			SCREW, MACHINE BRACKET MTG, PAN *HEAD, No. 8-32 THD SIZE, 1/2 IN. LG	EA		2							
0259	X2	0			SKID AND SPRING ASSEMBLY (COMPONENTS SAME AS SKID AND SPRING ASSEMBLY, STOCK No. (29201) A54484)	EA		1							
0260	X2	0			SKID AND SPRING ASSEMBLY	EA		1							
0261	X2	0			SPRING, SPIRAL	EA		4						D-5	69
0262	X2	0			SCREW, MACHINE: SPRING MTG, No. 10-32 THD SIZE, 3/8	EA		4						D-5	63
0263	X2	0			WASHER, FLAT: SPRING MTG	EA		4						D-5	65
0264	X2	0			NUT, SELF-LOCKING, HEXAGON: SPRING MTG, No. 10-32 THD SIZE	EA		4						D-5	68
0265	X2	0			SKID	EA		2						D-5	70
0266	X2	0			SCREW, MACHINE: SKID ASSEMBLY MTG, No. 10-32 THD SIZE, 9/16 IN LG, SPINLOCK	EA	4							D-5	67

LINE NO.	(1) SOURCE, MAINT AND RECOV CODE			(2)  FEDERAL STOCK NUMBER	(3)  DESCRIPTION	(4) UNIT OF ISSUE	(5) QTY INC IN UNIT PACK	(6) QTY INC IN UNIT	(7) 30-DAY DS/GS MAINT. ALW.			(8)  1 YR ALW PER 100 EQUIP  CTYGCY  PLANN- ING	(9)  DEPOT MAINT ALW PER 100 EQUIP	(10) ILLUS- TRATION			
	(A)	(B)	(C)						1-20	21-50	51-100			(A)	(B)		
	S	M	R														
	MANUFACTURER'S																
CODE	PART NUMBER																
0267	X2	O		6115-976-8884	WASHER, LOCK: SKID ASSEMBLY MTG, NO. 10 SCREW SIZE			4							D-5	64	
0268	X2	O			WASHER, FLAT: SKID ASSEMBLY MTG, NO. 10 SCREW SIZE	29201 83046-1	EA		8						D-5	66	
0269					GROUP 18 - BODY, CAB, HOOD AND HULL												
0270					1808 - STOWAGE RACKS, BOXES, CARRYING CASES												
0271	X2	O			CASE ASSEMBLY, CARRYING	74284 SK80400	EA		1								
0272	X2	O			BAG, SPARE PARTS	74284 SKS2573	EA		1								
0273					GROUP 22 - BODY, CHASSIS OR HULL AND ACCESSORY ITEMS												
0274					2210 - DATA PLATES												
0275	X2	F			PLATE, INSTRUCTION, ON-OFF	29201 72085-1	EA		1								
0276	X2	F			PLATE, IDENTIFICATION: NAME	29201 54545	EA		1								
0277	X2	F			PLATE, IDENTIFICATION	29201 54493	EA		1								
0278	X2	O			SCREW, DRIVE: PLATE MTG	29201 90129-1	EA		4								
0279	X2	O			PLATE, INSTRUCTION: STARTING	29201 54593	EA		1								
0280					GROUP 40 - ELECTRIC MOTORS AND GENERATORS												
0281					4001 - ROTOR ASSEMBLY												
0282	P	F			ROTOR, GENERATOR	00818 PMG3884	EA		1	*	2	2	18	5	D-5	4	
0283	X2	F			SCREW, MACHINE: ROTOR MTG, 1/4-28 THD SIZE, 3/4 IN. LG, SOCKET HEAD	28201 80526-1	EA		1						D-5	1	
0284	X2	F			WASHER, LOCK: ROTOR MTG, 1/4 IN. SCREW SIZE	29201 83009-1	EA		1						D-5	2	
0285	X2	F			WASHER, FLAT: ROTOR MTG, 1/4 IN. SCREW SIZE	29201 84095-1	EA		1						D-5	3	
0286					4002 - STATOR ASSEMBLY												
0287	X2	F			PLATE ASSEMBLY, STATOR MOUNTING	29201 A54486	EA		1								
0288	P	F			STATOR, GENERATOR	00818 PMG5754	EA		1	*	2	2	18	5	D-5	16	
0289	X2	F			SCREW, MACHINE: STATOR MTG, ROUND HEAD, SLOTTED, NO. 10-24 THD SIZE, 2 1/2 IN. LG.	29201 80993-1	EA		4						D-5	13	
0290	X2	F			WASHER, LOCK: STATOR MTG, NO. 10 THD SIZE	29201 83046-1	EA		4						D-5	14	

LINE NO.	(1) SOURCE, MAINT AND RECOV CODE			(2)  FEDERAL STOCK NUMBER	(3)  DESCRIPTION	(4) UNIT OF ISSUE	(5) QTY INC IN UNIT PACK	(6) QTY INC IN UNIT	(7) 30-DAY DS/GS MAINT. ALW.			(8)  1 YR ALW PER 100 EQUIP  CTYGCY  PLANN- ING	(9)  DEPOT MAINT ALW PER 100 EQUIP	(10) ILLUS- TRATION	
	(A)	(B)	(C)						(A)	(B)	(A)			(B)	
	S	M	R						1-20	21-50	51-100			FIG NO.	ITEM OR SYM NO.
	MANUFACTURER'S		CODE						PART NUMBER						
0291	X2	F			WASHER, FLAT: STATOR MTG	EA		4						D-5	15
0292	X2	F			GROMMET, RUBBER	EA		2						D-5	12
0293	X2	F			PLATE AND BEARING ASSEMBLY, STATOR	EA		1						D-5	
0294	P	F	3110-117-1347		BEARING, ROLLER NEEDLE	EA		1						D-5	18
0295	X1				PLATE, STATOR MOUNTING	EA		1						D-5	17
0296	X21	F			KEY, MACHINE	EA		1						D-5	19
0297	P	F	6115-976-883		SHAFT, GENERATOR	EA		1	*	2	2	18	3	D-5	20
0298	X2	F			SCREW, MACHINE: PLATE MTG	EA		4							
0299					4018 - TERMINAL BLOCKS, JUNCTION BOXES										
0300	X2	F			JUNCTION BOX	EA		1						D-5	8
0301	P	F	5935-755-3447		CONNECTOR ELECTRICAL RECEPTACLE	EA		1	2	3	5	60	10	D-5	9
0302	X2	F			SCREW, MACHINE: CONNECTOR MTG, ROUND HEAD, SLOTTED, No. 8-32 THD SIZE, 1/2 IN. LG										
0303	X2	F			WASHER, LOCK: CONNECTOR MTG, No. 8-32 THD SIZE	EA		2						D-5	6
0304	X2	F			STRAP, RETAINING	EA		2						D-5	7
0305	X2	F			SCREW, MACHINE: STOP MTG, PAN HEAD, No. 8-32 THD SIZE, 3/8 IN. LG	EA		1						D-5	11
0306	X2	F			SCREW, MACHINE: JUNCTION BOX MTG, No. 10-32 THD SIZE, 1/2 IN. LG	EA		1						D-5	10
						EA		1						D-5	5



**LEGEND TO PARTS, FIGURE D-1**

	<b>ITEM NO.</b>		<b>FUNCT GROUP</b>	<b>ITEM NAME</b>		
1	0605	SPARK PLUG		18	0104	PIN
2	0401	CLAMP		19	0104	RING
3	0401	ELBOW		20	0104	PISTON
4	0401	MUFFLER		21	0102	KEY
5	0401	NUT		22	0101	SEAL
6	0108	SCREW		23	0101	BEARING
7	0108	MANIFOLD		24	0102	WASHER
8	0101	NUT		25	0102	RACE
9	0101	WASHER		26	0102	BEARING
10	0101	CYLINDER		27	0102	CRANKSHAFT
11	0101	GASKET		28	0306	SCREW
12	0101	STUD		29	0101	CRANKCASE
13	0104	SCREW		30	0306	CAP
14	0104	ROLLER SET		31	0306	GASKET
15	0104	ROD AY		32	0306	VALVE
16	0104	BEARING		33	0306	ELBOW
17	0101	RING		34	0306	TANK AY

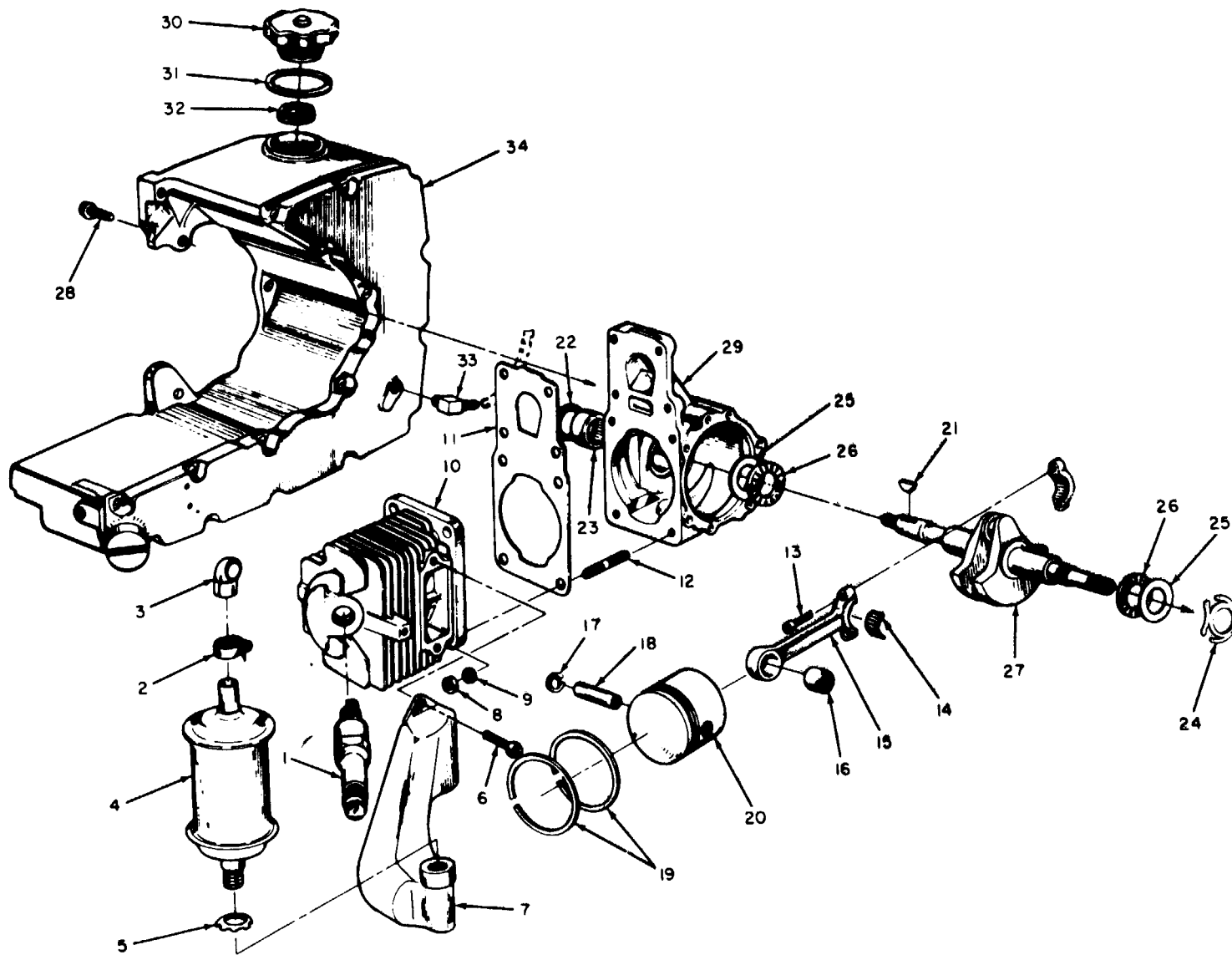

MEC 6115-405-15/D-1

FIGURE D-1. CRANKCASE CYLINDER, CRANKSHAFT AND RELATED PARTS

**LEGEND TO PARTS, FIGURE D-2**

<b>ITEM NO.</b>	<b>FUNCT GROUP</b>	<b>ITEM NAME</b>	<b>ITEM NO.</b>	<b>FUNCT GROUP</b>	<b>ITEM NAME</b>	<b>ITEM NO.</b>	<b>FUNCT GROUP</b>	<b>ITEM NAME</b>
1	0502	SCREW	19	0107	WASHER	37	0605	STUD
2	0502	SCREW	20	0502	NUT	38	0605	CLIP
3	0502	WASHER	21	0502	SCREEN	39	0605	SHIM
4	0502	HOUSING SUB AY	22	0103	NUT	40	0605	ARM GROUP
5	0107	INSERT	23	0103	WASHER	41	0605	CONTACT
6	0107	GRIP	24	0103	WASHER	42	0605	LEAD
7	0107	BUSHING	25	0107	STUD	43	0605	SCREW
8	0107	STARTER ROPE	26	0107	FINGER	44	0605	CLAMP
9	0605	TERMINAL	27	0107	WASHER	45	0605	CAPACITOR
10	0605	TERMINAL	28	0107	SPRING	46	0605	FELT
11	0605	READ AY	29	0103	ROTOR	47	0605	SCREW
12	0607	NUT	30	0605	COVER	48	0605	WEDGE
13	0607	SWITCH	31	0605	GASKET	49	0605	COIL
14	0107	SHIELD	32	0605	SPRING	50	0605	SCREW
15	0107	SPRING	33	0605	SCREW	51	0605	PLATE
16	0107	SHIELD	34	0605	NUT	52	0605	SEAL
17	0107	PULLEY	35	0605	WASHER	53	0605	GASKET
18	0107	SCREW	36	0605	CONNCTN UNIT			

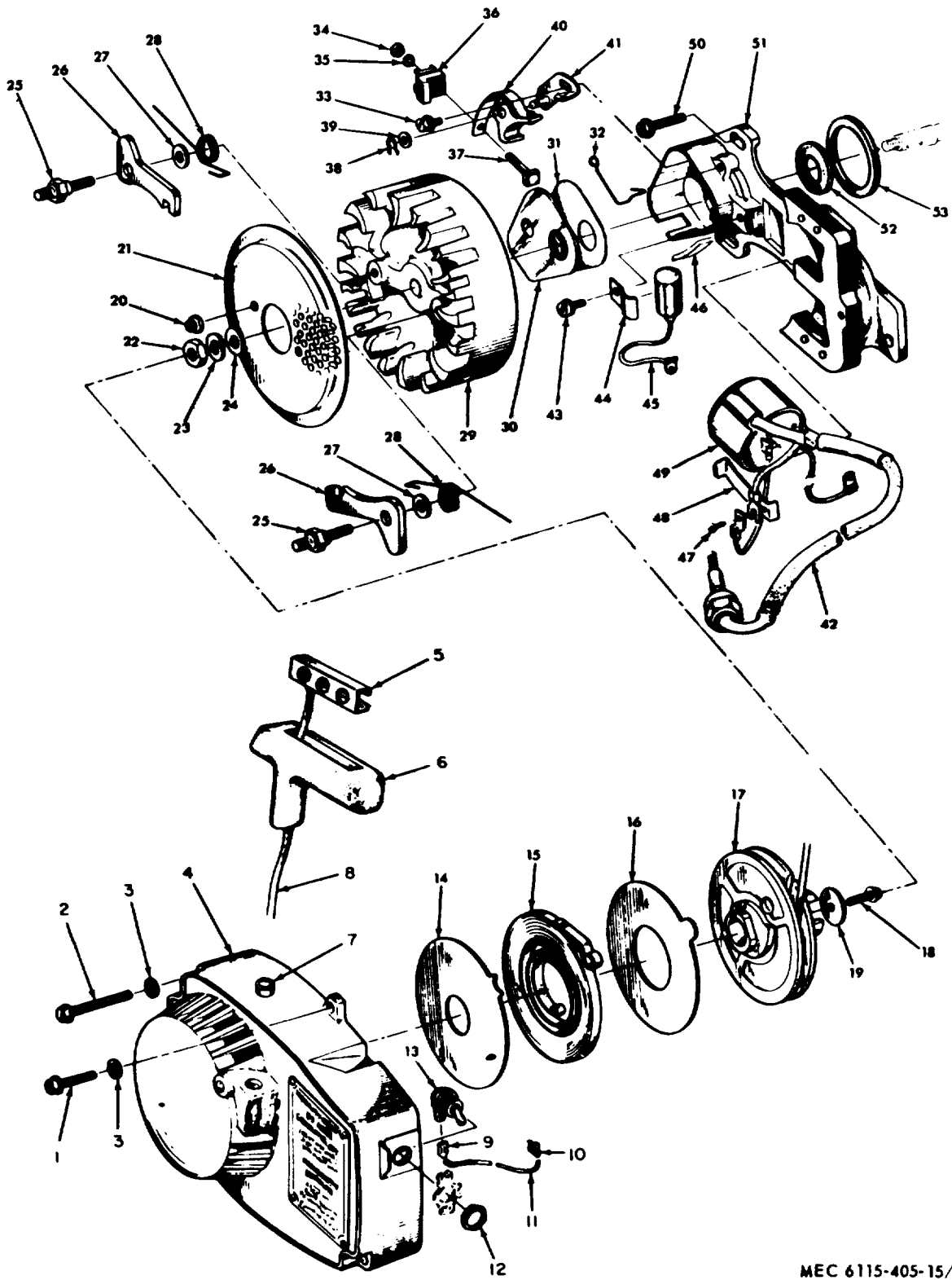

MEC 6115-405-15/D-2

FIGURE D-2. STARTER FAN HOUSING. STARTER PULLEY AND IGNITION COMPONENTS

**LEGEND TO PARTS, FIGURE D-3**

<b>ITEM NO.</b>	<b>FUNCT GROUP</b>	<b>ITEM NAME</b>	<b>ITEM NO.</b>	<b>FUNCT GROUP</b>	<b>ITEM NAME</b>
1	0301	SCREW	16	0301	PLUG
2	0301	WASHER	17	0301	NEEDLE
3	0301	COVER	18	0301	SCREW
4	0301	GASKET	19	0301	SPRING
5	0301	DIAPHRAGM	20	0301	SHAFT & LEVER
6	0301	SCREEN	21	0301	SHUTTER
7	0301	SCREW	22	0301	BALL
8	0301	WASHER	23	0301	SPRING
9	0301	COVER	24	0301	SCREW
10	0301	DIAPHRAGM	25	0301	WASHER
11	0301	GASKET	26	0301	CLIP
12	0301	SCREW	27	0301	SHUTTER
13	0301	PIN	28	0301	PIN
14	0301	LEVER	29	0301	SHAFT & LEVER
15	0301	SPRING	30	0301	BODY

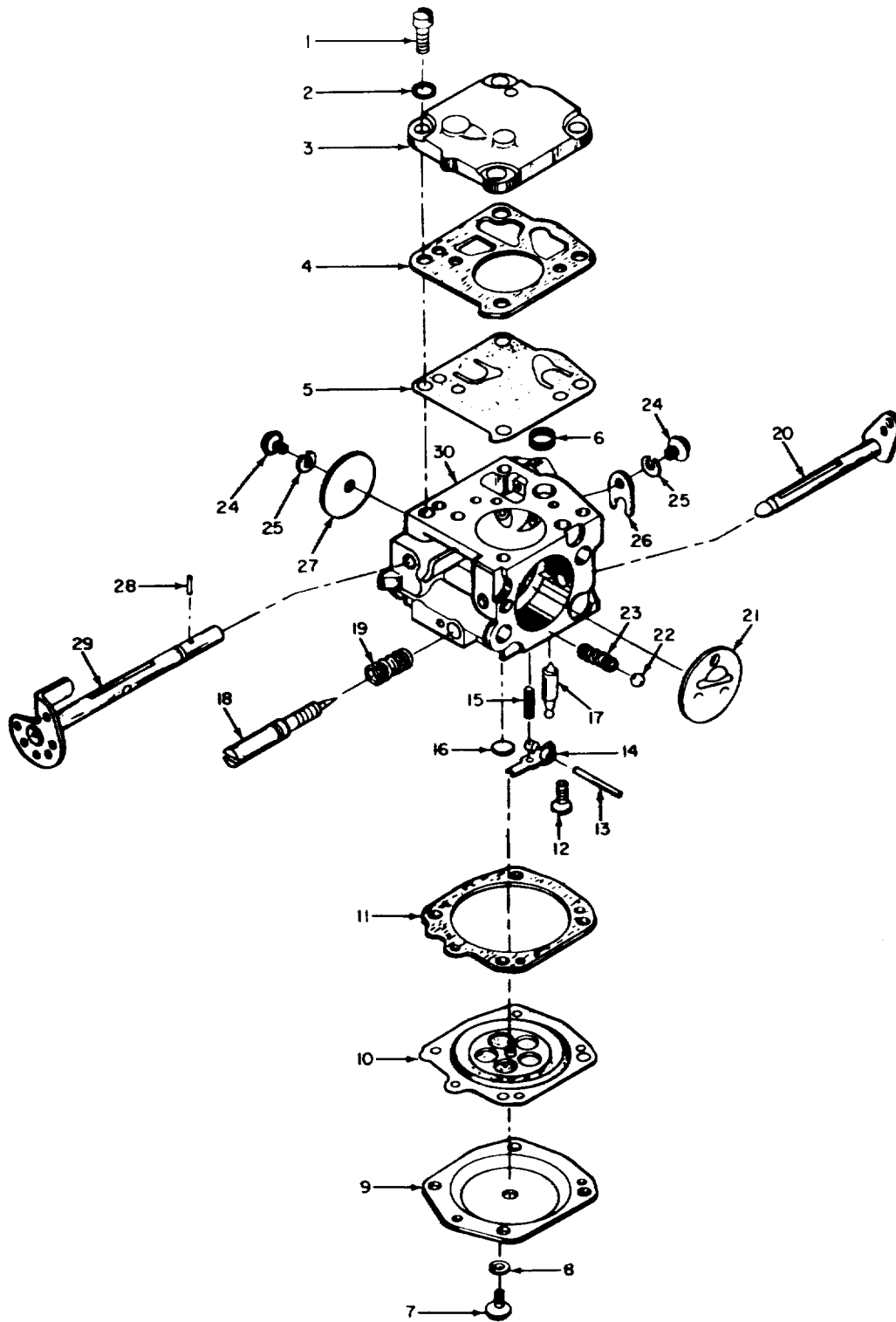

MEC 6115-405-15/D-3

FIGURE D-3. CARBURETOR

**LEGEND TO PARTS, FIGURE D-4**

<b>ITEM NO.</b>	<b>FUNCT GROUP</b>	<b>ITEM NAME</b>	<b>ITEM NO.</b>	<b>FUNCT GROUP</b>	<b>ITEM NAME</b>
1	0304	NUT	15	0306	SCREW
2	0304	COVER	16	0306	PLATE AY
3	0304	ELEMENT	17	0301	GROMMET
4	0304	RING	18	0301	PLUG
5	0304	GASKET	19	0301	CARBURETOR
6	0301	SCREW	20	0301	GASKET
7	0301	WASHER	21	0301	DAMPER
8	0304	BRACKET AY	22	0301	PIN
9	0301	PLUG	23	0301	SCREW
10	0312	BUTTON	24	0301	CHAMBER AY
11	0301	GROMMET	25	0301	SCREW
12	0312	PIN	26	0301	STOP
13	0312	ROD	27	0301	SPRING
14	0308	SPRING	28	0301	REED

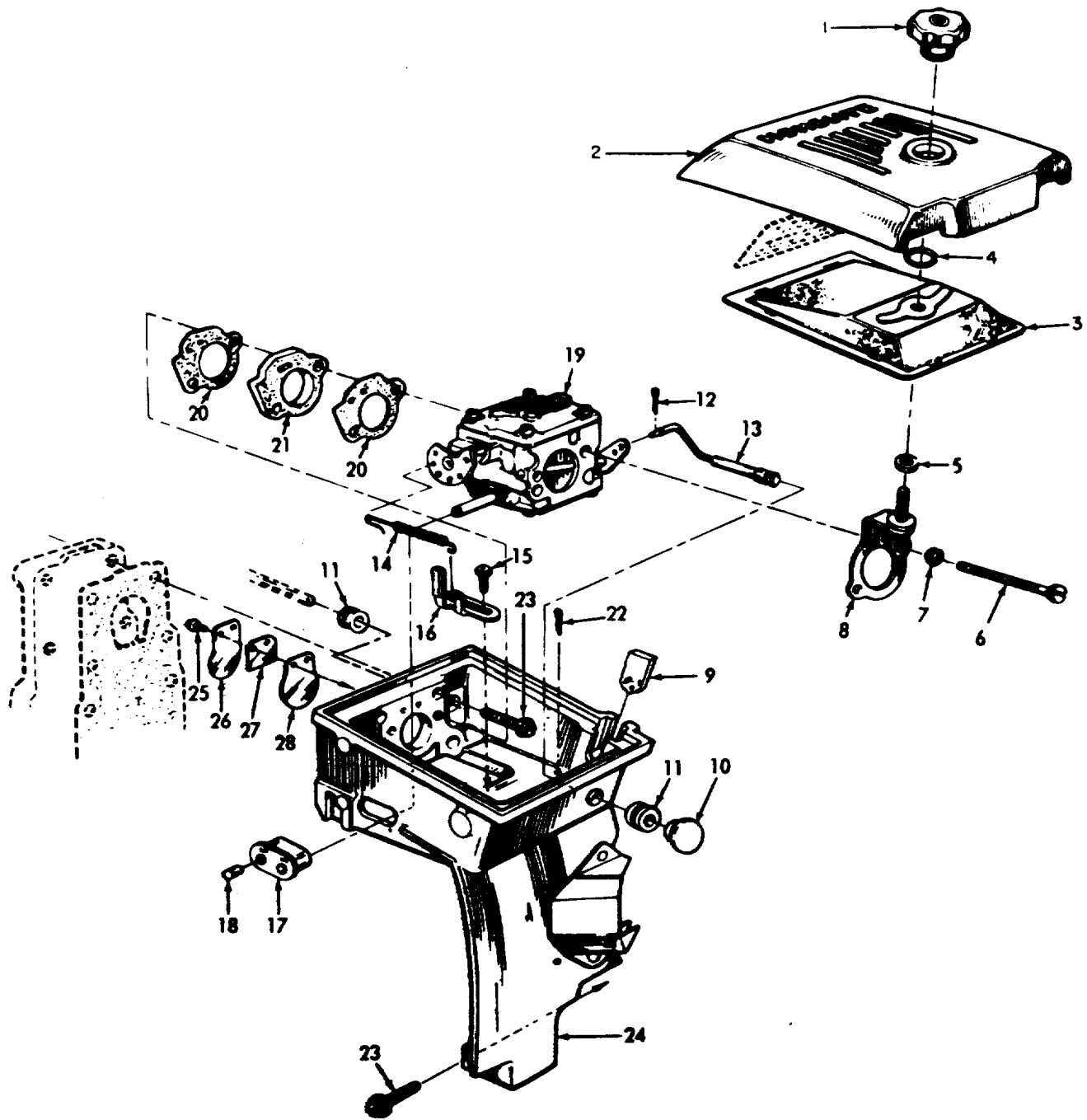

MEC 6115-405-15/D-4

FIGURE D-4. CARBURETOR CHAMBER



**LEGEND TO PARTS, FIGURE X**

<b>ITEM NO.</b>	<b>FUNCT GROUP</b>	<b>ITEM NAME</b>	<b>ITEM NO.</b>	<b>FUNCT GROUP</b>	<b>ITEM NAME</b>	<b>ITEM NO.</b>	<b>FUNCT GROUP</b>	<b>ITEM NAME</b>
1	4001	SCREW	24	0308	SCREW	48	0308	LINK
2	4001	WASHER	25	0308	WEIGHT	49	0308	WASHER
3	4001	WASHER	26	0308	ARM	50	0308	EXTENSION
4	4001	ROTOR	27	0308	CUP	51	0309	ELEMENT
5	4018	SCREW	28	0308	SPRING	52	0309	SHAFT
6	4018	SCREW	29	0308	WASHER	53	0306	LINE AY
7	4018	WASHER	30	0308	RING	54	0306	LINE
8	4018	JUNCTION BX	31	0101	SEAL	55	0306	LINE
9	4018	CONNECTOR	32	0101	SCREW	56	0306	SCREW
10	4018	SCREW	33	0101	BEARING	57	0306	NUT
11	4018	STRAP	34	0101	GASKET	58	0306	VALVE
12	0101	GROMMET	35	1501	SCREW	59	0306	SCREW
12	4002	GROMMET	36	1501	WASHER	60	0306	NUT
13	4002	SCREW	37	1501	GRIP	61	0306	WASHER
14	4002	WASHER	38	0308	SCREW	62	0306	BRACKET
15	4002	WASHER	39	0308	GUARD	63	1501	SCREW
16	4002	STATOR	40	1501	BRACKET	64	1501	WASHER
17	4002	PLATE AY	41	0308	SCREW	65	1501	WASHER
18	4002	BEARING	42	0308	WASHER	66	1501	WASHER
19	4002	KEY	43	0308	SCREW	67	1501	SCREW
20	4002	SHAFT	44	0308	WASHER	68	1501	NUT
21	0308	BACK PLATE	45	0308	CONNECTOR	69	1501	SPRING
22	0308	PIN	46	0308	CAM & SHAFT	70	1501	SKID
23	0308	PIN	47	0308	GUIDE	71	0101	DRIVE CASE

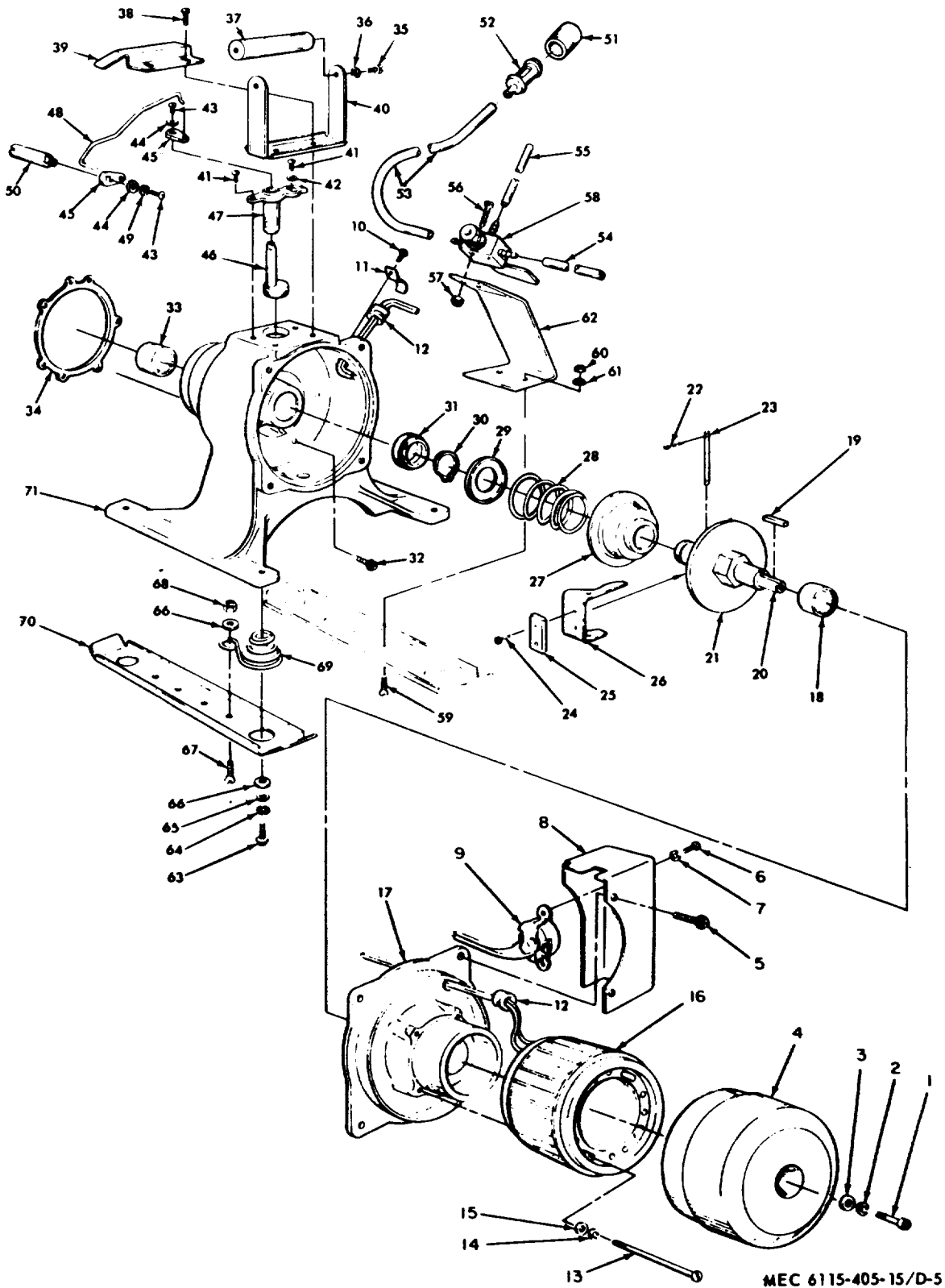

MEC 6115-405-15/D-5

FIGURE D-5. GENERATOR AND GOVERNOR

## INDEX

	Paragraph	Page
Adjustments:		
Carburetor .....	3-23	3-9
Governor.....	3-12	3-5
Ignition parts .....	6-4	6-1
Spark plug .....	3-11	3-5
Tabulated list .....	1-4	1-2
Air cleaner element.....	3-7	3-4
Basic issue tools and equipment .....	B-1	B-1
Carburetor assembly:		
Adjustments.....	3-23	3-8
Disassembly .....	6-18	6-13
Inspection and repair.....	6-19	6-13
Installation .....	5-14	5-15
Reassembly .....	6-20	6-15
Removal .....	5-14	5-15
Carburetor chamber:		
Disassembly .....	6-10	6-7
Inspection and repair.....	6-11	6-7
Reassembly .....	6-12	6-7
Controls and instruments .....	2-9	2-2
Cylinder exhaust port service .....	3-9	3-4
Description:		
Carrying case.....	1-3 <i>d</i>	1-2
Engine .....	1-3 <i>b</i>	1-1
General.....	1-3 <i>a</i>	1-1
Generator .....	1-3 <i>c</i>	1-1
Disassembly:		
Carburetor assembly .....	6-18	6-13
Carburetor chamber .....	6-10	6-7
Engine parts.....	6-14	6-12
Generator .....	6-6	6-4
Ignition parts .....	6-2	6-1
Starter fan housing.....	6-2	6-1
Dismantling for movement .....	2-6	2-2
Engine parts:		
Disassembly .....	6-14	6-12
Inspection and repair.....	6-15	6-12
Reassembly .....	6-16	6-12
Exhaust manifold service .....	3-9	3-4
Fuel line replacement.....	3-10	3-4
Fueling procedure .....	2-5 <i>c</i>	2-2
Generator:		
Disassembly .....	6-6	6-4
Inspection and repair.....	6-7	6-4
Installation .....	5-12	5-10
Reassembly .....	6-8	6-4

	Paragraph	Page
Removal .....	5-12	5-10
Governor speed adjustment .....	3-12	3-5
Identification .....	1-4a	1-2
Ignition parts:		
Adjustments .....	6-4	6-1
Disassembly .....	6-2	6-1
Inspection and repair .....	6-3	6-1
Reassembly .....	6-4	6-1
Removal .....	5-13	5-12
Inspecting and servicing equipment .....	2-3	2-1
Inspection and repair:		
Carburetor assembly .....	6-19	6-13
Carburetor chamber .....	6-11	6-7
Engine parts .....	6-15	6-12
Generator .....	6-7	6-4
Ignition parts .....	6-3	6-1
Starter fan housing .....	6-3	6-1
Installation:		
Carburetor .....	5-14	5-15
Generator .....	5-12	5-10
Generator set .....	2-5	2-1
Ignition parts .....	5-13	5-12
Starter fan housing .....	5-11	5-10
Maintenance allocation chart .....	C-1	C-1
Muffler .....	3-8	3-4
Operation:		
Dusty or sandy area .....	2-16	2-5
Extreme cold .....	2-14	2-4
Extreme heat .....	2-15	2-5
General .....	2-10	2-4
High altitudes .....	2-19	2-5
Rainy or humid conditions .....	2-17	2-5
Salt water areas .....	2-18	2-5
Starting .....	2-11	2-4
Stopping .....	2-12	2-4
Usual conditions .....	2-13	2-4
Preventive maintenance services:		
Daily .....	3-4	3-2
General .....	3-3	3-1
Quarterly .....	3-5	3-2
Radio interference suppression:		
Components .....	3-20, 5-8	3-8, 5-9
Definitions .....	3-18	3-8
Methods .....	3-19	3-8
Replacement of components .....	5-9	5-9
Reassembly:		
Carburetor assembly .....	6-20	6-15
Carburetor chamber .....	6-12	6-7
Engine parts .....	6-16	6-12
Generator .....	6-8	6-4
Ignition parts .....	6-4	6-1
Starter fan housing .....	6-4	6-1
Record and report forms .....	1-2, 4-2	1-1, 4-1
Removal:		
Carburetor .....	5-14	5-15
Generator .....	5-12	5-10

	Paragraph	Page
Ignition parts .....	5-31	5-12
Starter fan housing .....	5-11	5-10
Scope:		
Direct and general support and depot maintenance instructions .....	4-1	4-1
Introduction .....	1-1	1-1
Service:		
Air cleaner element .....	3-7	3-4
Cylinder exhaust port .....	3-9	3-4
Exhaust manifold .....	3-9	3-4
Fuel line .....	3-10	3-4
Muffler .....	3-8	3-4
Spark plug .....	3-11	3-5
Spark plug service .....	3-11	3-5
Special tools and equipment:		
Fabrication .....	5-2	5-1
Operator's and organizational maintenance .....	3-1	3-1
Starter fan housing:		
Disassembly .....	6-2	6-1
Inspection and repair .....	6-3	6-1
Installation .....	5-11	5-10
Reassembly .....	6-4	6-1
Removal .....	5-11	5-10
Tabulated data:		
Adjustments .....	1-4 <i>b</i> (5)	1-2
Carburetor .....	1-4 <i>b</i> (4) (a)	1-2
Dimensions and weights .....	1-4 <i>b</i> (7)	1-3
Engine .....	1-4 <i>b</i> (2)	1-2
Generator .....	1-4 <i>b</i> (3)	1-2
Generator classification and rating .....	4-4 <i>b</i>	4-1
Generator stator repair standards .....	4-4 <i>c</i>	4-1
Torque data .....	1-4 <i>b</i> (6), 4-4 <i>d</i> 1-2,4-1	
Troubleshooting:		
Engine .....	3-14--3-17	3-7, 3-8
General .....	5-4—5-6	5-9
Unloading equipment .....	3-13, 5-3	3-7, 5-9
Unpacking equipment .....	2-1	2-1
Unpacking equipment .....	2-2	2-1

By Order of the Secretary of the Army:

HAROLD K. JOHNSON,  
*General, United States Army,*  
*Chief of Staff.*

Official:

KENNETH G. WICKHAM,  
*Major General, United States Army,*  
*The Adjutant General*

Distribution:

Active Army:

USASA (2)  
 ACSI (1)  
 DCSLOG (1)  
 CNGB (1)  
 TSG (1)  
 CofEngrs (3)  
 Dir/Trans (1)  
 CofsptS (1)  
 USAMB (1)  
 USAARTYBD (2)  
 USA Armor Bd (2)  
 USAIB (2)  
 USARADB (2)  
 USAAESWBD (2)  
 USAAVNTBD (2)  
 USCONARC (3)  
 OS Maj Comd (5) except  
 USARJ (1)  
 USASETAF (2)  
 USAMC (1)  
 MDW (1)  
 Armies (2)  
 Corps (2)  
 Div (2)  
 Engr Bde (1)  
 Svc Colleges (2)  
 Br Sw Sch (2) except  
 USAES (6)  
 USACDCEC (10)  
 USMA (2)  
 GENDEP (10)  
 Engr Dep (10)

Army Dep (2) except  
 TOAD (3)  
 MOTBA (2)  
 MOTBY (2)  
 MOTKI (2)  
 MOTSU (2)  
 EAMTMTS (1)  
 CAMTMTS (1)  
 WAMTMTS (1)  
 Div Engr (2)  
 Engr Dist (2)  
 USAERDL (3)  
 USAMECOM (46)  
 Engr Cen (5)  
 USAREUR Engr Proc Cen (2)  
 USAREUR Engr Sup Con Agcy (10)  
 Engr FLDMS (2)  
 Fort Knox FLDMS (10)  
 Fld Comd, DASA (8)  
 AMS (3)  
 USAREURCOMZ (2)  
 USAC (1)  
 MAAG (1)  
 JBUSMC (1)  
 Units org under fol TOE:  
 5-48 (2)  
 5-237 (5)  
 5-262 (5)  
 5-267 (1)  
 5-278 (5)  
 5-279 (2)

NG: State AG (3)

USAR: Same as active Army except allowance is one (1) copy for each unit.

For explanation of abbreviations used, see AR 320-50.

RECOMMENDED CHANGES TO EQUIPMENT TECHNICAL PUBLICATIONS

 <div style="border: 1px solid black; border-radius: 15px; padding: 5px; display: inline-block; margin-left: 10px;"> <p style="margin: 0;"><i>THEN...JOT DOWN THE DOPE ABOUT IT ON THIS FORM. CAREFULLY TEAR IT OUT, FOLD IT AND DROP IT IN THE MAIL.</i></p> </div>		SOMETHING WRONG WITH PUBLICATION	
		FROM: (PRINT YOUR UNIT'S COMPLETE ADDRESS)	
PUBLICATION NUMBER		DATE SENT	
PUBLICATION DATE		PUBLICATION TITLE	
BE EXACT PIN-POINT WHERE IT IS			
PAGE NO.	PARA- GRAPH	FIGURE NO.	TABLE NO.
<div style="text-align: center; font-weight: bold; margin-bottom: 20px;">IN THIS SPACE, TELL WHAT IS WRONG AND WHAT SHOULD BE DONE ABOUT IT.</div> <div style="border: 1px dashed black; width: 20%; margin: 0 auto; height: 20px;"></div>			
PRINTED NAME, GRADE OR TITLE AND TELEPHONE NUMBER			SIGN HERE

## The Metric System and Equivalents

### Linear Measure

1 centimeter = 10 millimeters = .39 inch  
 1 decimeter = 10 centimeters = 3.94 inches  
 1 meter = 10 decimeters = 39.37 inches  
 1 dekameter = 10 meters = 32.8 feet  
 1 hectometer = 10 dekameters = 328.08 feet  
 1 kilometer = 10 hectometers = 3,280.8 feet

### Weights

1 centigram = 10 milligrams = .15 grain  
 1 decigram = 10 centigrams = 1.54 grains  
 1 gram = 10 decigrams = .035 ounce  
 1 decagram = 10 grams = .35 ounce  
 1 hectogram = 10 decagrams = 3.52 ounces  
 1 kilogram = 10 hectograms = 2.2 pounds  
 1 quintal = 100 kilograms = 220.46 pounds  
 1 metric ton = 10 quintals = 1.1 short tons

### Liquid Measure

1 centiliter = 10 milliliters = .34 fl. ounce  
 1 deciliter = 10 centiliters = 3.38 fl. ounces  
 1 liter = 10 deciliters = 33.81 fl. ounces  
 1 dekaliter = 10 liters = 2.64 gallons  
 1 hectoliter = 10 dekaliters = 26.42 gallons  
 1 kiloliter = 10 hectoliters = 264.18 gallons

### Square Measure

1 sq. centimeter = 100 sq. millimeters = .155 sq. inch  
 1 sq. decimeter = 100 sq. centimeters = 15.5 sq. inches  
 1 sq. meter (centare) = 100 sq. decimeters = 10.76 sq. feet  
 1 sq. dekameter (are) = 100 sq. meters = 1,076.4 sq. feet  
 1 sq. hectometer (hectare) = 100 sq. dekameters = 2.47 acres  
 1 sq. kilometer = 100 sq. hectometers = .386 sq. mile

### Cubic Measure

1 cu. centimeter = 1000 cu. millimeters = .06 cu. inch  
 1 cu. decimeter = 1000 cu. centimeters = 61.02 cu. inches  
 1 cu. meter = 1000 cu. decimeters = 35.31 cu. feet

## Approximate Conversion Factors

<i>To change</i>	<i>To</i>	<i>Multiply by</i>	<i>To change</i>	<i>To</i>	<i>Multiply by</i>
inches	centimeters	2.540	ounce-inches	Newton-meters	.007062
feet	meters	.305	centimeters	inches	.394
yards	meters	.914	meters	feet	3.280
miles	kilometers	1.609	meters	yards	1.094
square inches	square centimeters	6.451	kilometers	miles	.621
square feet	square meters	.093	square centimeters	square inches	.155
square yards	square meters	.836	square meters	square feet	10.764
square miles	square kilometers	2.590	square meters	square yards	1.196
acres	square hectometers	.405	square kilometers	square miles	.386
cubic feet	cubic meters	.028	square hectometers	acres	2.471
cubic yards	cubic meters	.765	cubic meters	cubic feet	35.315
fluid ounces	milliliters	29.573	cubic meters	cubic yards	1.308
pints	liters	.473	milliliters	fluid ounces	.034
quarts	liters	.946	liters	pints	2.113
gallons	liters	3.785	liters	quarts	1.057
ounces	grams	28.349	liters	gallons	.264
pounds	kilograms	.454	grams	ounces	.035
short tons	metric tons	.907	kilograms	pounds	2.205
pound-feet	Newton-meters	1.356	metric tons	short tons	1.102
pound-inches	Newton-meters	.11296			

### Temperature (Exact)

°F	Fahrenheit temperature	5/9 (after subtracting 32)	Celsius temperature	°C
----	------------------------	----------------------------	---------------------	----



TM 5-6115-405-15 GENERATOR SET, GASOLINE ENGINE: 0.125KW, AC 115V, SINGLE PHASE -1967

PIN: 025630-000